

**GENERAL APTITUDE**

**Q. No. 1 - 5 Carry One Mark Each**

1. "India is a country of rich heritage and cultural diversity." Which one of the following facts best supports the claim made in the above sentence?

- (A) India is a union of 28 states and 7 union territories
- (B) India has a population of over 1.1 billion
- (C) India is home to 22 official languages and thousands of dialects
- (D) The Indian cricket team draws players from over ten states

**Answer: (C)**

---

2. The value of one U.S. dollar is 65 Indian Rupees today, compared to 60 last year. The Indian Rupee has \_\_\_\_\_.

- (A) Depressed
- (B) Depreciated
- (C) Appreciated
- (D) Stabilized

**Answer: (B)**

---

3. 'Advice' is \_\_\_\_\_.

- (A) a verb
- (B) a noun
- (C) an adjective
- (D) both a verb and a noun

**Answer: (B)**

---

4. The next term in the series 81, 54, 36, 24 ... is \_\_\_\_\_.

**Answer: (16)**

---

5. In which of the following options will the expression  $P < M$  be definitely true?

- (A)  $M < R > P > S$
- (B)  $M > S < P < F$
- (C)  $Q < M < F = P$
- (D)  $P = A < R < M$

**Answer: (D)**

---

Q. No. 6 – 10 Carry Two Marks Each

6. Find the next term in the sequence: 7G, 11K, 13M, \_\_\_\_  
 (A) 15Q                      (B) 17Q                      (C) 15P                      (D) 17P

**Answer: (B)**

7. The multi-level hierarchical pie chart shows the population of animals in a reserve forest. The correct conclusions from this information are:

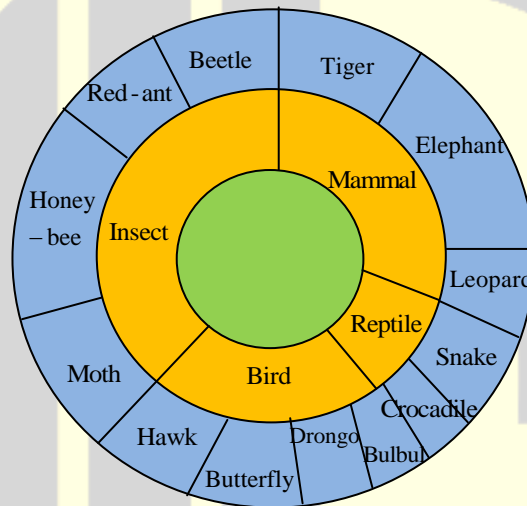

- (i) Butterflies are birds  
 (ii) There are more tigers in this forest than red ants  
 (iii) All reptiles in this forest are either snakes or crocodiles  
 (iv) Elephants are the largest mammals in this forest  
 (A) (i) and (ii) only                      (B) (i), (ii), (iii) and (iv)  
 (C) (i), (iii) and (iv) only                      (D) (i), (ii) and (iii) only

**Answer: (D)**

8. A man can row at 8 km per hour in still water. If it takes him thrice as long to row upstream, as to row downstream, then find the stream velocity in km per hour.

**Answer: (4)**

9. A firm producing air purifiers sold 200 units in 2012. The following pie chart presents the share of raw material, labour, energy, plant & machinery, and transportation costs in the total manufacturing cost of the firm in 2012.

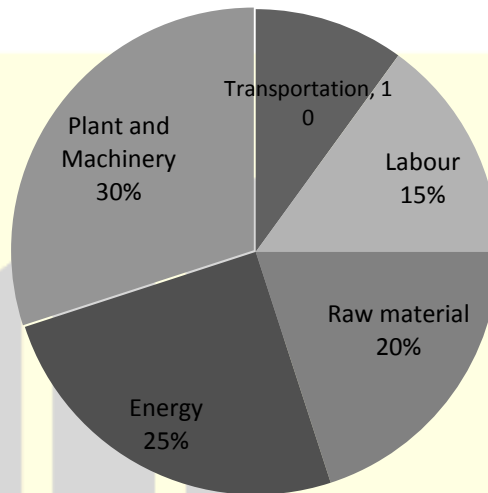

The expenditure on labour in 2012 is Rs. 4,50,000. In 2013, the raw material expenses increased by 30% and all other expenses increased by 20%. If the company registered a profit of Rs. 10 lakhs in 2012, at what price (in Rs.) was each air purifier sold?

**Answer: (20,000)**

10. A batch of one hundred bulbs is inspected by testing four randomly chosen bulbs. The batch is rejected if even one of the bulbs is defective. A batch typically has five defective bulbs. The probability that the current batch is accepted is \_\_\_\_\_.

**Answer: (0.8145)**

**MECHANICAL ENGINEERING****Q. No. 1 – 25 Carry One Mark Each**

1. Consider a  $3 \times 3$  real symmetric matrix  $S$  such that two of its eigen values are  $a \neq 0, b \neq 0$  with respective

eigenvectors  $\begin{bmatrix} x_1 \\ x_2 \\ x_3 \end{bmatrix}, \begin{bmatrix} y_1 \\ y_2 \\ y_3 \end{bmatrix}$ . If  $a \neq b$  then  $x_1y_1 + x_2y_2 + x_3y_3$  equals

- (A)  $a$                       (B)  $b$                       (C)  $ab$                       (D)  $0$

**Answer: (D)**

2. If a function is continuous at a point,

- (A) The limit of the function may not exist at the point  
(B) The function must be derivable at the point  
(C) The limit of the function at the point tends to infinity  
(D) The limit must exist at the point and the value of limit should be same as the value of the function at that point

**Answer: (D)**

3. Divergence of the vector field  $x^2\hat{i} + xy\hat{j} - yz^2\hat{k}$  at  $(1, -1, 1)$  is

- (A)  $0$                       (B)  $3$                       (C)  $5$                       (D)  $6$

**Answer: (C)**

4. A group consists of equal number of men and women. Of this group 20% of the men and 50% of the women are unemployed. If a person is selected at random from this group, the probability of the selected person being employed is \_\_\_\_\_.

**Answer: (0.64 to 0.66)**

5. The definite integral  $\int_1^3 \frac{1}{x} dx$  is evaluated using Trapezoidal rule with a step size of 1. The correct answer is \_\_\_\_\_.

**Answer: (1.1 to 1.2)**

6. A rotating steel shaft is supported at the ends. It is subjected to a point load at the centre. The maximum bending stress developed is 100 MPa. If the yield, ultimate and corrected endurance strength of the shaft material is 300 MPa, 500 MPa and 200 MPa, respectively, then the factor of safety for the shaft is \_\_\_\_\_.

**Answer: (1.9 to 2.1)**

7. Two solid circular shafts of radii  $R_1$  and  $R_2$  are subjected to same torque. The maximum shear stresses developed in the two shafts are  $\tau_1$  and  $\tau_2$ . If  $R_1/R_2=2$ , then  $\tau_2/\tau_1$  is \_\_\_\_\_.

**Answer: (7.9 to 8.1)**

8. Consider a single degree-of-freedom system with viscous damping excited by a harmonic force. At resonance, the phase angle (in degree) of the displacement with respect to the exciting force is
- (A) 0                      (B) 45                      (C) 90                      (D) 135

**Answer: (C)**

9. A mass  $m_1$  of 100 kg travelling with a uniform velocity of 5 m/s along a line collides with a stationary mass  $m_2$  of 1000 kg. After the collision, both the masses travel together with the same velocity. The coefficient of restitution is
- (A) 0.6                      (B) 0.1                      (C) 0.01                      (D) 0

**Answer: (D)**

10. Which one of following is **NOT** correct?
- (A) Intermediate principal stress is ignored when applying the maximum principal stress theory
- (B) The maximum shear stress theory gives the most accurate results amongst all the failure theories
- (C) As per the maximum strain energy theory, failure occurs when the strain energy per unit volume exceeds a critical value

- (D) As per the maximum distortion energy theory, failure occurs when the distortion energy per unit volume exceeds a critical value

**Answer: (B)**

11. Gear 2 rotates at 1200 rpm in counter clockwise direction and engages with Gear 3. Gear 3 and Gear 4 are mounted on the same shaft. Gear 5 engages with Gear 4. The numbers of teeth on Gears 2, 3, 4 and 5 are 20, 40, 15 and 30, respectively.

The angular speed of Gear 5 is

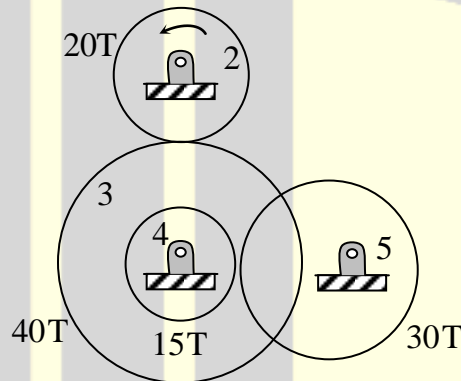

- (A) 300 rpm counter clockwise      (B) 300 rpm clockwise  
(C) 4800 rpm counter clockwise      (D) 4800 rpm clockwise

**Answer: (A)**

12. Consider a long cylindrical tube of inner and outer radii,  $r_i$  and  $r_o$ , respectively, length,  $L$  and thermal conductivity,  $k$ . Its inner and outer surfaces are maintained at  $T_i$  and  $T_o$ , respectively ( $T_i > T_o$ ). Assuming one-dimensional steady state heat conduction in the radial direction, the thermal resistance in the wall of the tube is

(A)  $\frac{1}{2\pi kL} \ln\left(\frac{r_i}{r_o}\right)$       (B)  $\frac{1}{2\pi r_i k}$       (C)  $\frac{1}{2\pi r_i k} \ln\left(\frac{r_o}{r_i}\right)$       (D)  $\frac{1}{4\pi r_i k} \ln\left(\frac{r_o}{r_i}\right)$

**Answer: (C)**

13. Which one of the following pairs of equations describes an irreversible heat engine?

(A)  $\oint \delta Q > 0$  and  $\oint \frac{\delta Q}{T} < 0$

(B)  $\oint \delta Q < 0$  and  $\oint \frac{\delta Q}{T} < 0$

(C)  $\oint \delta Q > 0$  and  $\oint \frac{\delta Q}{T} > 0$

(D)  $\oint \delta Q < 0$  and  $\oint \frac{\delta Q}{T} > 0$

**Answer: (A)**

14. Consider the turbulent flow of a fluid through a circular pipe of diameter,  $D$ . Identify the correct pair of statements.

I. The fluid is well-mixed

II. The fluid is unmixed

III.  $Re_D < 2300$

IV.  $Re_D > 2300$

(A) I, III

(B) II, IV

(C) II, III

(D) I, IV

**Answer: (D)**

15. For a gas turbine power plant, identify the correct pair of statements.

P. Smaller in size compared to steam power plant for same power output  
Starts quickly compared to steam power plant

R. Works on the principle of Rankine cycle

S. Good compatibility with solid fuel

(A) P, Q

(B) R, S

(C) Q, R

(D) P, S

**Answer: (A)**

16. A source at a temperature of 500 K provides 1000 kJ of heat. The temperature of environment is 27°C. The maximum useful work (in kJ) that can be obtained from the heat source is \_\_\_\_\_

**Answer: (399 to 401)**

17. A sample of moist air at a total pressure of 85 KPa has a dry bulb temperature of 30°C (saturation vapour pressure of water = 4.24 KPa). If the air sample has a relative humidity of 65%, the absolute humidity (in gram) of water vapour per kg of dry air is \_\_\_\_\_.

**Answer: (19 to 22)**

---

18. The process utilizing mainly thermal energy for removing material is
- (A) Ultrasonic Machining (B) Electrochemical Machining  
(C) Abrasive Jet Machining (D) Laser Beam Machining

**Answer: (D)**

---

19. The actual sales of a product in different months of a particular year are given below:

September	October	November	December	January	February
180	280	250	190	240	?

The forecast of the sales, using the 4-month moving average method, for the month of February is \_\_\_\_\_.

**Answer: (239 to 241)**

---

20. A straight turning operation is carried out using a single point cutting tool on an AISI 1020 steel rod. The feed is 0.2 mm/rev and the depth of cut is 0.5 mm. The tool has a side cutting edge angle of 60°. The uncut chip thickness (in mm) is \_\_\_\_\_.

**Answer: (0.08 to 0.12)**

---

21. A minimal spanning tree in network flow models involves
- (A) All the nodes with cycle/loop allowed  
(B) All the nodes with cycle/loop not allowed  
(C) Shortest path between start and end nodes  
(D) All the nodes with directed arcs

**Answer: (B)**



22. Match the casting defects (Group A) with the probable causes (Group B):

Group A	Group B
(p) Hot tears	1: Improper fusion of two streams of liquid metal
(q) Shrinkage	2: Low permeability of the sand mould
(r) Blow holes	3: Volumetric contraction both in liquid and solid stage
(s) Cold Shut	4: Differential cooling rate

(A) P-1, Q-3, R-2, S-4

(B) P-4, Q-3, R-2, S-1

(C) P-3, Q-4, R-2, S-1

(D) P-1, Q-2, R-4, S-3

**Answer: (B)**

23. Cutting tool is much harder than the workpiece. Yet the tool wears out during the tool-work interaction, because

- (A) extra hardness is imparted to the workpiece due to coolant used
- (B) oxide layers on the workpiece surface impart extra hardness to it
- (C) extra hardness is imparted to the workpiece due to severe rate of strain
- (D) vibration is induced in the machine tool

**Answer: (C)**

24. The stress-strain curve for mild steel is shown in the figure given below. Choose the correct option referring to both figure and table.

Point on the graph	Description of the point
P	1. Upper Yield Point
Q	2. Ultimate Tensile Strength
R	3. Proportionality Limit
S	4. Elastic Limit
T	5. Lower Yield Point
U	6. Failure

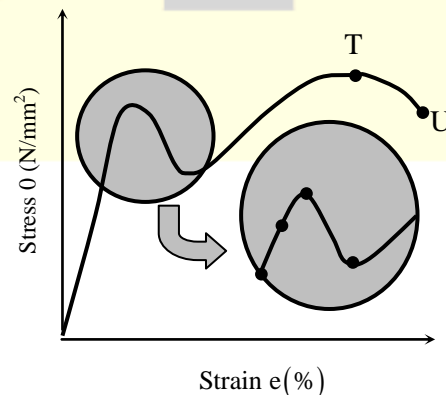

- (A) P-1, Q-2, R-3, S-4, T-5, U-6                      (B) P-3, Q-1, R-4, S-2, T-6, U-5  
(C) P-3, Q-4, R-1, S-5, T-2, U-6                      (D) P-4, Q-1, R-5, S-2, T-3, U-6

**Answer: (C)**

**25.** The hot tearing in a metal casting is due to

- (A) high fluidity  
(B) high melt temperature  
(C) wide range of solidification temperature  
(D) low coefficient of thermal expansion

**Answer: (C)**

Q. No. 26 – 55 Carry Two Marks Each

**26.** An analytic function of a complex variable  $z = x + iy$  is expressed as  $f(z) = w(x, y) + iv(x, y)$ , where  $i = \sqrt{-1}$ . If  $u(x, y) = x^2 - y^2$ , then expression for  $v(x, y)$  in terms of  $x, y$  and a general constant  $c$  would be

- (A)  $xy + c$                       (B)  $\frac{x^2 + y^2}{2} + c$                       (C)  $2xy + c$                       (D)  $\frac{(x - y)^2}{2} + c$

**Answer: (C)**

**27.** Consider two solutions  $x(t) = x_1(t)$  and  $x(t) = x_2(t)$  of the differential equation

$$\frac{d^2x(t)}{dt^2} + x(t) = 0, t > 0, \text{ Such that } x_1(0) = 1, 1, \left. \frac{dx_1(t)}{dt} \right|_{t=0} = 0, x_2(0) = 0, \left. \frac{dx_2(t)}{dt} \right|_{t=0} = 1.$$

The Wronskian  $W(t) = \begin{vmatrix} x_1(t) & x_2(t) \\ \frac{dx_1(t)}{dt} & \frac{dx_2(t)}{dt} \end{vmatrix}$  at  $t = \frac{\pi}{2}$  is

- (A) 1                      (B) -1                      (C) 0                      (D)  $\frac{\pi}{2}$

**Answer: (A)**

28. A machine produces 0, 1 or 2 defective pieces in a day with associated probability of  $1/6$ ,  $2/3$  and  $1/6$ , respectively. The mean value and the variance of the number of defective pieces produced by the machine in a day, respectively, are
- (A) 1 and  $1/3$       (B)  $1/3$  and 1      (C) 1 and  $4/3$       (D)  $1/3$  and  $4/3$

**Answer: (A)**

29. The real root of the equation  $5x - 2\cos x - 1 = 0$  (up to two decimal accuracy) is \_\_\_\_\_.

**Answer: (0.53 to 0.56)**

30. A drum brake is shown in the figure. The drum is rotating in anticlockwise direction. The coefficient of friction between drum and shoe is 0.2. The dimensions shown in the figure are in mm.

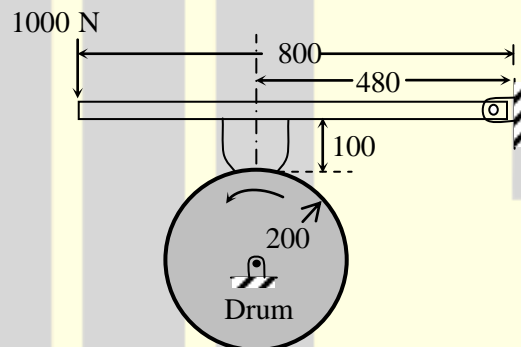

The braking torque (in N.m) for the brake shoe is \_\_\_\_\_.

**Answer: (63 to 65)**

31. A body of mass ( $M$ ) 10 kg is initially stationary on a  $45^\circ$  inclined plane as shown in figure. The coefficient of dynamic friction between the body and the plane is 0.5. The body slides down the plane and attains a velocity of 20 m/s.

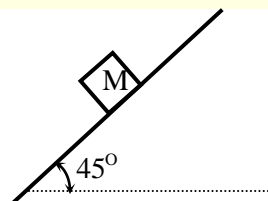

The distance travelled (in meter) by the body along the plane is \_\_\_\_\_.

**Answer: (56 to 59)**

**32.** Consider a simply supported beam of length,  $50h$ , with a rectangular cross-section of depth,  $h$ , and width,  $2h$ . The beam carries a vertical point load,  $P$ , at its mid-point. The ratio of the maximum shear stress to the maximum bending stress in the beam is

- (A) 0.02                      (B) 0.10                      (C) 0.05                      (D) 0.01

**Answer: (D)**

**33.** The damping ratio of a single degree of freedom spring-mass-damper system with mass of 1 kg, stiffness 100 N/m and viscous damping coefficient of 25 N.s/m is \_\_\_\_\_.

**Answer: (1.24 to 1.26)**

**34.** An annular disc has a mass  $m$ , inner radius  $R$  and outer radius  $2R$ . The disc rolls on a flat surface without slipping. If the velocity of the centre of mass is  $v$ , the kinetic energy of the disc is

- (A)  $\frac{9}{16}mv^2$                       (B)  $\frac{11}{16}mv^2$                       (C)  $\frac{13}{16}mv^2$                       (D)  $\frac{15}{16}mv^2$

**Answer: (C)**

**35.** A force  $P$  is applied at a distance  $x$  from the end of the beam as shown in the figure. What would be the value of  $x$  so that the displacement at 'A' is equal to zero?

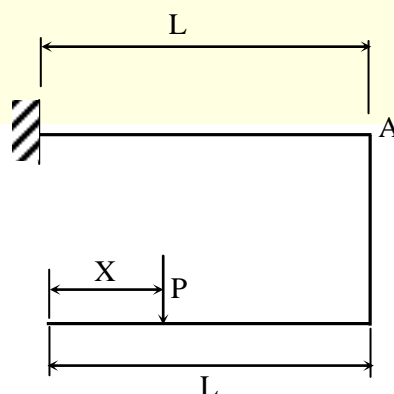

- (A) 0.5L                      (B) 0.25L                      (C) 0.33L                      (D) 0.66L

**Answer: (C)**

**36.** Consider a rotating disk cam and a translating roller follower with zero offset. Which one of the following pitch curves, parameterized by  $t$ , lying in the interval  $0$  to  $2\pi$ , is associated with the maximum translation of the follower during one full rotation of the cam rotating about the center at  $(x, y) = (0, 0)$  ?

- (A)  $x(t) = \cos t, y(t) = \sin t$                       (B)  $x(t) = \cos t, y(t) = 2\sin t$   
 (C)  $x(t) = \frac{1}{2} + \cos t, y(t) = 2\sin t$                       (D)  $x(t) = \frac{1}{2} + \cos t, y(t) = \sin t$

**Answer: (C)**

**37.** A four-wheel vehicle of mass 1000 kg moves uniformly in a straight line with the wheels revolving at 10 rad/s. The wheels are identical, each with a radius of 0.2 m. Then a constant braking torque is applied to all the wheels and the vehicle experiences a uniform deceleration. For the vehicle to stop in 10 s, the braking torque (in N.m) on each wheel is \_\_\_\_\_.

**Answer: (9 to 11)**

**38.** A slider-crank mechanism with crank radius 60 mm and connecting rod length 240 mm is shown in figure. The crank is rotating with a uniform angular speed of 10 rad/s, counter clockwise.

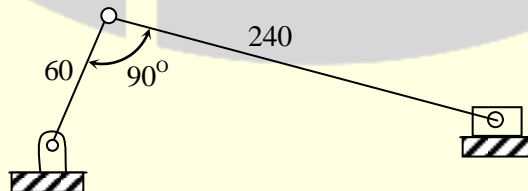

For the given configuration, the speed (in m/s) of the slider is \_\_\_\_\_.

**Answer: (0.54 to 0.68)**

39. Consider an objective function  $Z(x_1, x_2) = 3x_1 + 9x_2$  and the constraints

$$x_1 + x_2 \leq 8,$$

$$x_1 + 2x_2 \leq 4,$$

$$x_1 \geq 0, x_2 \geq 0,$$

The maximum value of the objective function is \_\_\_\_\_.

**Answer: (17 to 19)**

40. A mass-spring-dashpot system with mass  $m = 10$  kg, spring constant  $k = 6250$  N/m is excited by a harmonic excitation of  $10 \cos(25t)$  N. At the steady state, the vibration amplitude of the mass is 40 mm.

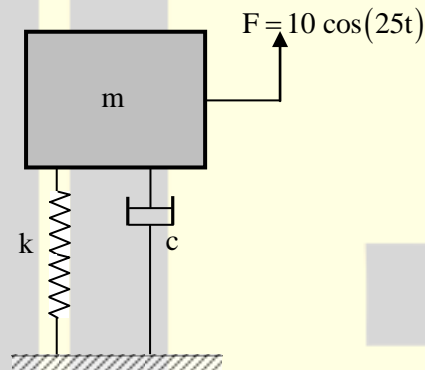

The damping coefficient ( $c$ , in N.s/m) of the dashpot is \_\_\_\_\_.

**Answer: (9 to 11)**

41. A certain amount of an ideal gas is initially at a pressure  $P_1$  and temperature  $T_1$ . First, it undergoes a constant pressure process 1-2 such that  $T_2 = 3T_1/4$ . Then, it undergoes a constant volume process 2-3 such that  $T_3 = T_1/2$ . The ratio of the final volume to the initial volume of the ideal gas is

(A) 0.25                      (B) 0.75                      (C) 1.0                      (D) 1.5

**Answer: (B)**



The conductivity of one section is  $k$  and that of the other is  $2k$ . The left face of the wall is at 600 K and the right face is at 300 K. The interface temperature  $T_i$  (in K) of the composite wall is \_\_\_\_\_.

**Answer: (399 to 401)**

45. A fluid of dynamic viscosity  $2 \times 10^{-5}$  kg/m.s and density  $1 \text{ kg/m}^3$  flows with an average velocity of 1 m/s through a long duct of rectangular ( $25 \text{ mm} \times 15 \text{ mm}$ ) cross-section. Assuming laminar flow, the pressure drop (in Pa) in the fully developed region per meter length of the duct is \_\_\_\_\_.

**Answer: (1.7 to 2.0)**

46. At the inlet of an axial impulse turbine rotor, the blade linear speed is 25 m/s, the magnitude of absolute velocity is 100 m/s and the angle between them is  $25^\circ$ .

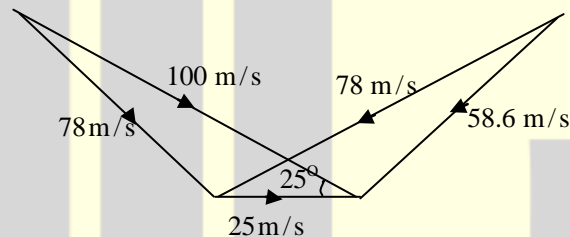

The relative velocity and the axial component of velocity remain the same between the inlet and outlet of the blades. The blade inlet and outlet velocity triangles are shown in the figure. Assuming no losses, the specific work (in J/kg) is \_\_\_\_\_.

**Answer: (3250 to 3300)**

47. A solid sphere of radius  $r_1 = 20 \text{ mm}$  is placed concentrically inside a hollow sphere of radius  $r_2 = 30 \text{ mm}$  as shown in the figure.

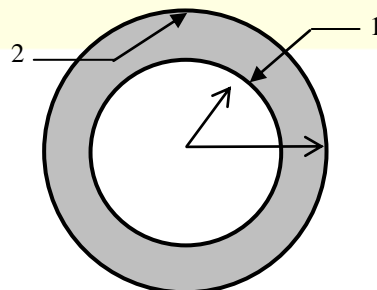



The view factor  $F_{21}$  for radiation heat transfer is

- (A)  $\frac{2}{3}$                       (B)  $\frac{4}{9}$                       (C)  $\frac{8}{27}$                       (D)  $\frac{9}{4}$

**Answer: (B)**

- 48.** A double-pipe counter-flow heat exchanger transfers heat between two water streams. Tube side water at 19 liter/s is heated from  $10^{\circ}\text{C}$  to  $38^{\circ}\text{C}$ . Shell side water at 25 liter/s is entering at  $46^{\circ}\text{C}$ . Assume constant properties of water, density is  $1000 \text{ kg/m}^3$  and specific heat is  $4186 \text{ J/kg K}$ . The LMTD (in  $^{\circ}\text{C}$ ) is \_\_\_\_\_.

**Answer: (10.8 to 11.2)**

- 49.** A diesel engine has a compression ratio of 17 and cut-off take place at 10% of the stroke. Assuming ratio of specific heats ( $\gamma$ ) as 1.4, the air-standard efficiency (in percent) is \_\_\_\_\_.

**Answer: (58 to 62)**

- 50.** Consider the given project network, where numbers along various activities represent the normal time. The free float on activity 4-6 and the project duration, respectively, are

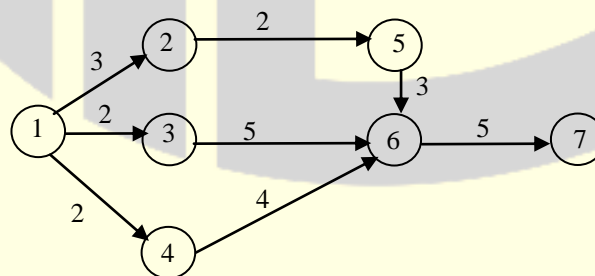

- (A) 2, 13                      (B) 0, 13                      (C) -2, 13                      (D) 2, 12

**Answer: (A)**

51. A manufacturer can produce 12000 bearings per day. The manufacturer received an order of 8000 bearings per day from a customer. The cost of holding a bearing in stock is Rs.0.20 per month. Setup cost per production run is Rs.500. Assuming 300 working days in a year, the frequency of production run should be
- (A) 4.5 days            (B) 4.5 months            (C) 6.8 days            (D) 6.8 months

**Answer: (C)**

52. A cylindrical blind riser with diameter  $d$  and height  $h$ , is placed on the top of the mold cavity of a closed type sand mold as shown in the figure. If the riser is of constant volume, then the rate of solidification in the riser is the least when the ratio  $h/d$  is

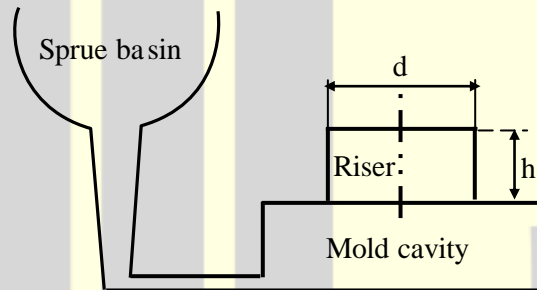

- (A) 1:2            (B) 2:1            (C) 1:4            (D) 4:1

**Answer: (A)**

53. The diameter of a recessed ring was measured by using two spherical balls of diameter  $d_2 = 60$  mm and  $d_1 = 40$  mm as shown in the figure.

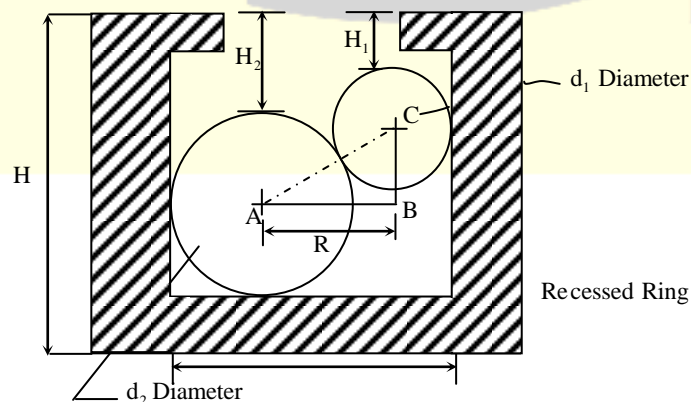

The distance  $H_2 = 35.55$  mm and  $H_1 = 20.55$  mm. The diameter ( $D$ , in mm) of the ring gauge is \_\_\_\_\_.

**Answer: (92 to 94)**

---

**54.** Which pair of following statements is correct for orthogonal cutting using a single-point cutting tool?

**P.** Reduction in friction angle increases cutting force

Reduction in friction angle decreases cutting force

**R.** Reduction in friction angle increases chip thickness

**S.** Reduction in friction angle decreases chip thickness

(A) P and R

(B) P and S

(C) Q and R

(D) Q and S

**Answer: (D)**

---

**55.** For spot welding of two steel sheets (base metal) each of 3 mm thickness, welding current of 10000 A is applied for 0.2s. The heat dissipated to the base metal is 1000 J. Assuming that the heat required for melting  $1 \text{ mm}^3$  volume of steel is 20 J and interfacial contact resistance between sheets is  $0.0002 \Omega$ , the volume (in  $\text{mm}^3$ ) of weld nugget is \_\_\_\_\_.

**Answer: (140 to 160)**

---

**★★★ END OF THE PAPER ★★★**