

GENERAL APTITUDE

Q. No. 1 - 5 Carry One Mark Each

1. Which of the following options is the closest in meaning to the word underlined in the sentence below?

In a democracy, everybody has the freedom to disagree with the government.

- (A) dissent (B) descent (C) decent (D) decadent

Answer: (A)

2. After the discussion, Tom said to me, 'Please revert!' He expects me to _____.

- (A) retract (B) get back to him
(C) move in reverse (D) retreat

Answer: (B)

3. While receiving the award, the scientist said, "I feel vindicated". Which of the following is closest in meaning to the word 'vindicated'?

- (A) punished (B) substantiated (C) appreciated (D) chastened

Answer: (B)

4. Let $f(x, y) = x^n y^m = P$. If x is doubled and y is halved, the new value of f is

- (A) $2^{n-m}P$ (B) $2^{m-n}P$ (C) $2(n-m)P$ (D) $2(m-n)P$

Answer: (A)

5. In a sequence of 12 consecutive odd numbers, the sum of the first 5 numbers is 425. What is the sum of the last 5 numbers in the sequence?

Answer: (495)

Q. No. 6 – 10 Carry Two Marks Each

6. Find the next term in the sequence: 13M, 17Q, 19S, _____
(A) 21W (B) 21V (C) 23W (D) 23V

Answer: (C)

7. If 'KCLFTSB' stands for 'best of luck' and 'SHSWDG' stands for 'good wishes', which of the following indicates 'ace the exam'?
- (A) MCHTX (B) MXHTC (C) XMHCT (D) XMHTC

Answer: (B)

8. Industrial consumption of power doubled from 2000-2001 to 2010-2011. Find the annual rate of increase in percent assuming it to be uniform over the years.
- (A) 5.6 (B) 7.2 (C) 10.0 (D) 12.2

Answer: (B)

9. A firm producing air purifiers sold 200 units in 2012. The following pie chart presents the share of raw material, labour, energy, plant & machinery, and transportation costs in the total manufacturing cost of the firm in 2012.

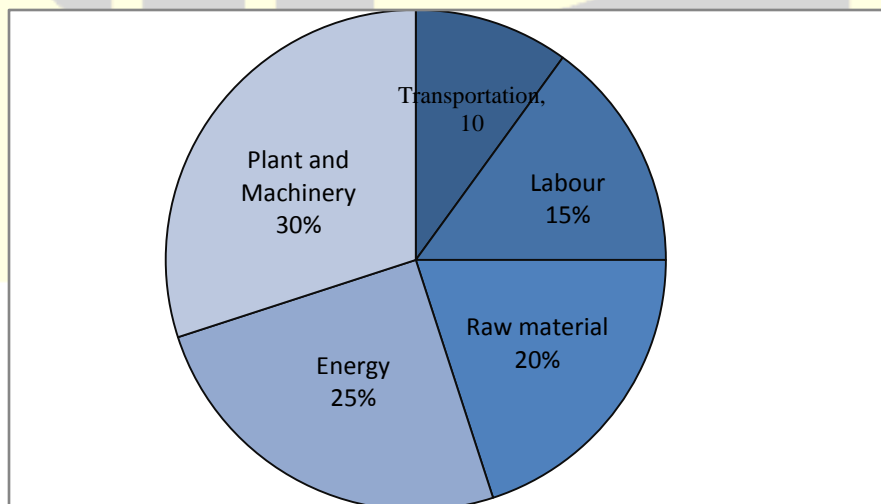

The expenditure on labour in 2012 is Rs. 4,50,000. In 2013, the raw material expenses increased by 30% and all other expenses increased by 20%. What is the percentage increase in total cost for the company in 2013?

Answer: (22)

10. A five digit number is formed using the digits 1,3,5,7 and 9 without repeating any of them. What is the sum of all such possible five digit numbers?

- (A) 6666660 (B) 6666600 (C) 6666666 (D) 6666606

Answer: (B)

Q. No. 1 – 25 Carry One Mark Each

1. Which one of the following equations is a correct identity for arbitrary 3×3 real matrices P, Q and R?

- (A) $P(Q+R) = PQ + RP$ (B) $(P-Q)^2 = P^2 - 2PQ + Q^2$
(C) $\det(P+Q) = \det P + \det Q$ (D) $(P+Q)^2 = P^2 + PQ + QP + Q^2$

Answer: (D)

2. The value of the integral $\int_0^2 \frac{(x-1)^2 \sin(x-1)}{(x-1)^2 + \cos(x-1)} dx$ is

- (A) 3 (B) 0 (C) -1 (D) -2

Answer: (B)

3. The solution of the initial value problem $\frac{dy}{dx} = -2xy$; $y(0) = 2$ is

- (A) $1 + e^{-x^2}$ (B) $2e^{-x^2}$ (C) $1 + e^{x^2}$ (D) $2e^{x^2}$

Answer: (B)

4. A nationalized bank has found that the daily balance available in its savings accounts follows a normal distribution with a mean of Rs. 500 and a standard deviation of Rs. 50. The percentage of savings account holders, who maintain an average daily balance more than Rs 500 is _____.

Answer: (49 to 51)

5. Laplace transform of $\cos(\omega t)$ is $\frac{s}{s^2 + \omega^2}$. The laplace transform of $e^{-2t} \cos(4t)$ is

(A) $\frac{s-2}{(s-2)^2 + 16}$

(B) $\frac{s+2}{(s-2)^2 + 16}$

(C) $\frac{s-2}{(s+2)^2 + 16}$

(D) $\frac{s+2}{(s+2)^2 + 16}$

Answer: (D)

6. In a statically determinate plane truss, the number of joints (j) and the number of members (m) are related by

(A) $j = 2m - 3$

(B) $m = 2j + 1$

(C) $m = 2j - 3$

(D) $m = 2j - 1$

Answer: (C)

7. If the Poisson's ratio of an elastic material is 0.4, the ratio of modulus of rigidity to Young's modulus is _____.

Answer: (0.35 to 0.36)

8. Which one of the following is used to convert a rotational motion into a translational motion?

(A) Bevel gears

(B) Double helical gears

(C) Worm gears

(D) Rack and pinion gears

Answer: (D)

9. The number of independent elastic constants required to define the stress-strain relationship for an isotropic elastic solid is _____.

Answer: (1.9 to 2.1)

10. A point mass is executing simple harmonic motion with an amplitude of 10 mm and frequency of 4 Hz. The maximum acceleration (m/s^2) of the mass is _____.

Answer: (6.3 to 6.4)

11. Ball bearings are rated by a manufacturer for a life of 10^6 revolutions. The catalogue rating of a particular bearing is 16 kN. If the design load is 2 kN, the life of the bearing will be $p \times 10^6$ revolutions, where p is equal to _____.

Answer: (500 to 540)

12. As the temperature increases, the thermal conductivity of a gas
- (A) increases
 - (B) decreases
 - (C) remains constant
 - (D) increases up to a certain temperature and then decreases

Answer: (A)

13. A reversed Carnot cycle refrigerator maintains a temperature of -5°C . The ambient air temperature is 35°C . The heat gained by the refrigerator at a continuous rate is 2.5 kJ/s. The power (in watt) required to pump this heat out continuously is _____.

Answer: (370 to 375)

14. A flow field which has only convective acceleration is
- (A) a steady uniform flow (B) an unsteady uniform flow
(C) a steady non-uniform flow (D) an unsteady non-uniform flow

Answer: (C)

15. Match Group A with Group B:

Group A	Group B
P: Biot number	1: Ratio of buoyancy to viscous force
Q: Grashof number	2: Ratio of inertia force to viscous force
R: Prandtl number	3: Ratio of momentum to thermal diffusivities
S: Reynolds number	4: Ratio of internal thermal resistance to boundary layer thermal resistance

- (A) P-4, Q-1, R-3, S-2 (B) P-4, Q-3, R-1, S-2
(C) P-3, Q-2, R-1, S-4 (D) P-2, Q-1, R-3, S-4

Answer: (A)

16. Kaplan water turbine is commonly used when the flow through its runner is
- (A) axial and the head available is more than 100 m
(B) axial and the head available is less than 10 m
(C) radial and the head available is more than 100 m
(D) mixed and the head available is about 50 m

Answer: (B)

17. Moist air at 35°C and 100% relative humidity is entering a psychrometric device and leaving at 25°C and 100% relative humidity. The name of the device is

- (A) Humidifier (B) Dehumidifier (C) Sensible heater (D) Sensible cooler

Answer: (B)

- 18.** The total number of decision variables in the objective function of an assignment problem of size $n \times n$ (n jobs and n machines) is

- (A) n^2 (B) $2n$ (C) $2n - 1$ (D) n

Answer: (A)

- 19.** Demand during lead time with associated probabilities is shown below:

Demand	50	70	75	80	85
Probability	0.15	0.14	0.21	0.20	0.30

Expected demand during lead time is _____.

Answer: (74 to 75)

- 20.** Within the Heat Affected Zone (HAZ) in a fusion welding process, the work material undergoes

- (A) microstructural changes but does not melt
(B) neither melting nor microstructural changes
(C) both melting and microstructural changes after solidification
(D) melting and retains the original microstructure after solidification

Answer: (A)

- 21.** Two separate slab milling operations, 1 and 2, are performed with identical milling cutters. The depth of cut in operation 2 is twice that in operation 1. The other cutting parameters are identical.

The ratio of maximum uncut chip thicknesses in operations 1 and 2 is _____.

Answer: (0.70 to 0.72)

22. The principle of material removal in Electrochemical machining is
- (A) Fick's law (B) Faraday's laws
(C) Kirchhoff's laws (D) Ohm's law

Answer: (B)

23. Better surface finish is obtained with a large rake angle because
- (A) the area of shear plane decreases resulting in the decrease in shear force and cutting force
(B) the tool becomes thinner and the cutting force is reduced
(C) less heat is accumulated in the cutting zone
(D) the friction between the chip and the tool is less

Answer: (A)

24. Match the heat treatment processes (Group A) and their associated effects on properties (Group B) of medium carbon steel:

Group A	Group B
P: Tempering	I: Strengthening and grain refinement
Q: Quenching	II: Inducing toughness
R: Annealing	III: Hardening
S: Normalizing	IV: Softening

- (A) P-III, Q-IV, R-II, S-I (B) P-II, Q-III, R-IV, S-I
(C) P-III, Q-II, R-IV, S-I (D) P-II, Q-III, R-I, S-IV

Answer: (B)

25. In a rolling process, the maximum possible draft, defined as the difference between the initial and the final thickness of the metal sheet, mainly depends on which pair of the following parameters

P: Strain

Q: Strength of the work material

R: Roll diameter

S: Roll velocity

T: Coefficient of friction between roll and work

(A) Q, S

(B) R, T

(C) S, T

(D) P, R

Answer: (B)

Q. No. 26 – 55 Carry Two Marks Each

26. If z is a complex variable, the value of $\int_5^{3i} \frac{dz}{z}$ is

(A) $-0.511 - 1.57i$

(B) $-0.511 + 1.57i$

(C) $0.511 - 1.57i$

(D) $0.511 + 1.57i$

Answer: (B)

27. The value of integral $\int_0^2 \int_0^x e^{x+y} dy dx$ is

(A) $\frac{1}{2}(e-1)$

(B) $\frac{1}{2}(e^2-1)^2$

(C) $\frac{1}{2}(e^2-e)$

(D) $\frac{1}{2}\left(e-\frac{1}{e}\right)^2$

Answer: (B)

28. The number of accidents occurring in a plant in a month follows Poisson distribution with mean as 5.2.

The probability of occurrence of less than 2 accidents in the plant during a randomly selected month is

(A) 0.029

(B) 0.034

(C) 0.039

(D) 0.044

Answer: (B)

29. Consider an ordinary differential equation . $\frac{dx}{dt} = 4t + 4$. If $x = x_0$ at $t = 0$, the increment in x calculated using Runge-Kutta fourth order multi-step method with a step size of $\Delta t = 0.2$ is
- (A) 0.22 (B) 0.44 (C) 0.66 (D) 0.88

Answer: (D)

30. A shaft is subjected to pure torsional moment. The maximum shear stress developed in the shaft is 100 MPa. The yield and ultimate strengths of the shaft material in tension are 300 MPa and 450 MPa, respectively. The factor of safety using maximum distortion energy (von-Mises) theory is _____.

Answer: (1.7 to 1.8)

31. A thin gas cylinder with an internal radius of 100 mm is subject to an internal pressure of 10 MPa. The maximum permissible working stress is restricted to 100 MPa. The minimum cylinder wall thickness (in mm) for safe design must be _____.

Answer: (9.8 to 10.6)

32. For the truss shown in the figure, the forces F_1 and F_2 are 9 kN and 3 kN, respectively. The force (in kN) in the member QS is

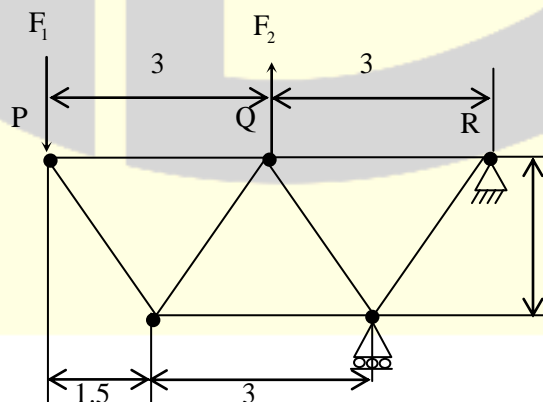

All dimensions are in m

- (A) 11.25 tension (B) 11.25 compression
(C) 13.5 tension (D) 13.5 compression

Answer: (A)

33. It is desired to avoid interference in a pair of spur gears having a 20° pressure angle. With increase in pinion to gear speed ratio, the minimum number of teeth on the pinion
- (A) increases (B) decreases
(C) first increases and then decreases (D) remains unchanged

Answer: (A)

34. A uniform slender rod (8 m length and 3 kg mass) rotates in a vertical plane about a horizontal axis 1 m from its end as shown in the figure.

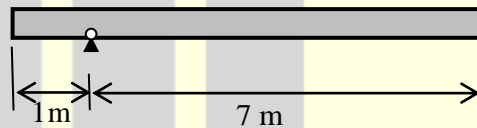

The magnitude of the angular acceleration (in rad/s^2) of the rod at the position shown is _____.

Answer: (1.9 to 2.1)

35. A bolt of major diameter 12 mm is required to clamp two steel plates. Cross sectional area of the threaded portion of the bolt is 84.3 mm^2 . The length of the threaded portion in grip is 30 mm, while the length of the unthreaded portion in grip is 8 mm. Young's modulus of material is 200 GPa. The effective stiffness (in MN/m) of the bolt in the clamped zone is _____.

Answer: (460 to 470)

36. A frame is subjected to a load P as shown in the figure. The frame has a constant flexural rigidity EI . The effect of axial load is neglected. The deflection at point A due to the applied load P is

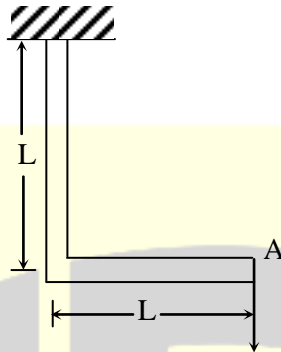

- (A) $\frac{1}{3} \frac{PL^3}{EI}$ (B) $\frac{2}{3} \frac{PL^3}{EI}$ (C) $\frac{PL^3}{EI}$ (D) $\frac{4}{3} \frac{PL^3}{EI}$

Answer: (D)

37. A wardrobe (mass 100 kg, height 4 m, width 2 m, depth 1 m), symmetric about the $Y-Y$ axis, stands on a rough level floor as shown in the figure. A force P is applied at mid-height on the wardrobe so as to tip it about point Q without slipping. What are the minimum values of the force (in Newton) and the static coefficient of friction μ between the floor and the wardrobe, respectively?

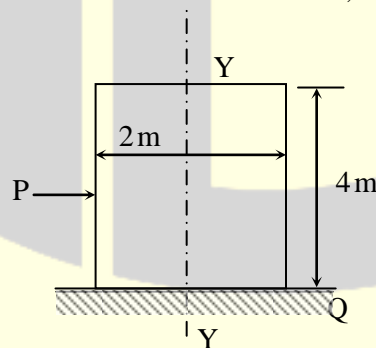

- (A) 490.5 and 0.5 (B) 981 and 0.5
(C) 1000.5 and 0.15 (D) 1000.5 and 0.25

Answer: (A)

38. Torque and angular speed data over one cycle for a shaft carrying a flywheel are shown in the figures. The moment of inertia (in $\text{kg}\cdot\text{m}^2$) of the flywheel is _____

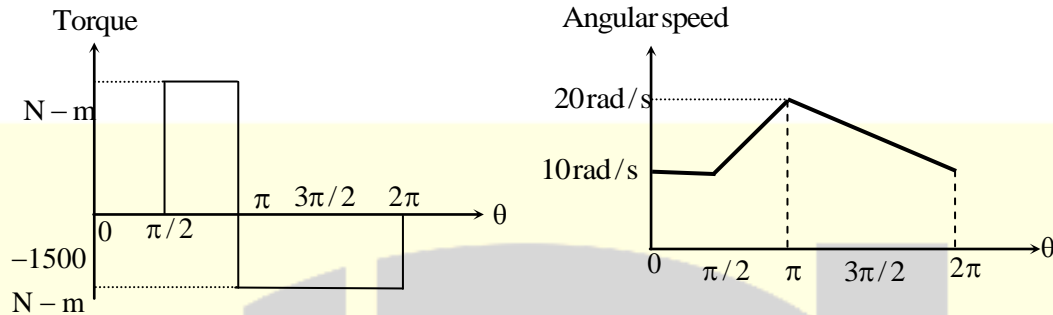

Answer: (30 to 32)

39. A single degree of freedom system has a mass of 2 kg, stiffness 8 N/m and viscous damping ratio 0.02 . The dynamic magnification factor at an excitation frequency of 1.5 rad/s is _____.

Answer: (2.0 to 2.4)

40. A ladder AB of length 5 m and weight (W) 600 N is resting against a wall. Assuming frictionless contact at the floor (B) and the wall (A), the magnitude of the force P (in Newton) required to maintain equilibrium of the ladder is _____

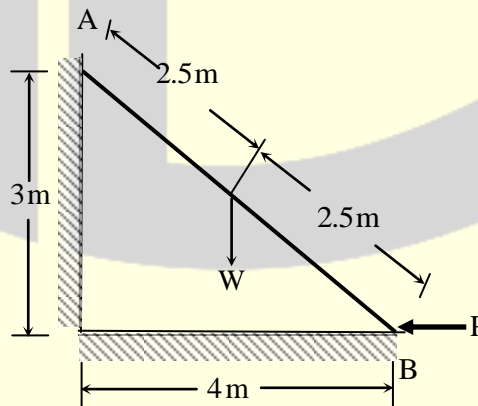

Answer: (399 to 401)

41. A closed system contains 10 kg of saturated liquid ammonia at 10°C. Heat addition required to convert the entire liquid into saturated vapour at a constant pressure is 16.2 MJ. If the entropy of the saturated liquid is 0.88 kJ/kg.K, the entropy (in kJ/kg.K) of saturated vapour is _____.

Answer: (6.4 to 6.7)

42. A plane wall has a thermal conductivity of 1.15 W/m.K. If the inner surface is at 1100°C and the outer surface is at 350°C, then the design thickness (in meter) of the wall to maintain a steady heat flux of 2500 W/m² should be _____.

Answer: (0.33 to 0.35)

43. Consider the following statements regarding streamline(s):

- (i) It is a continuous line such that the tangent at any point on it shows the velocity vector at that point
- (ii) There is no flow across streamlines
- (iii) $\frac{dx}{u} = \frac{dy}{v} = \frac{dz}{w}$ is the differential equation of a streamline, where u , v and w are velocities in directions x , y and z , respectively
- (iv) In an unsteady flow, the path of a particle is a streamline

Which one of the following combinations of the statements is true?

- (A) (i), (ii), (iv) (B) (ii), (iii), (iv) (C) (i), (iii), (iv) (D) (i), (ii), (iii)

Answer: (D)

44. Consider a velocity field $\vec{V} = K(y\hat{i} + x\hat{k})$, where K is a constant. The vorticity, Ω_z , is

- (A) $-K$ (B) K (C) $-K/2$ (D) $K/2$

Answer: (A)

45. Water flows through a tube of diameter 25 mm at an average velocity of 1.0m/s. The properties of water $\rho = 1000\text{kg/m}^3$, $\mu = 7.25 \times 10^{-4} \text{ N.s/m}^2$, $k = 0.625 \text{ W/mK}$, $\text{Pr} = 4.85$. Using $\text{Nu} = 0.023\text{Re}^{0.8} \text{Pr}^{0.4}$, the convective heat transfer coefficient (in $\text{W/m}^2\cdot\text{K}$) is _____.

Answer: (4600 to 4625)

46. Two identical metal blocks L and M (specific heat = 0.4 kJ/kg.K), each having a mass of 5 kg, are initially at 313 K. A reversible refrigerator extracts heat from block L and rejects heat to block M until the temperature of block L reaches 293 K. The final temperature (in K) of block M is _____.

Answer: (333 to 335)

47. Steam with specific enthalpy (h) 3214 kJ/kg enters an adiabatic turbine operating at steady state with a flow rate 10 kg/s. As it expands, at a point where h is 2920 kJ/kg, 1.5 kg/s is extracted for heating purposes. The remaining 8.5 kg/s further expands to the turbine exit, where $h = 2374$ kJ/kg. Neglecting changes in kinetic and potential energies, the net power output (in kW) of the turbine is _____.

Answer: (7580 to 7582)

48. Two infinite parallel plates are placed at a certain distance apart. An infinite radiation shield is inserted between the plates without touching any of them to reduce heat exchange between the plates. Assume that the emissivities of plates and radiation shield are equal. The ratio of the net heat exchange between the plates with and without the shield is

(A) 1/2 (B) 1/3 (C) 1/4 (D) 1/8

Answer: (A)

49. In a compression ignition engine, the inlet air pressure is 1 bar and the pressure at the end of isentropic compression is 32.42 bar. The expansion ratio is 8. Assuming ratio of specific heats (γ) as 1.4, the air standard efficiency (in percent) is _____.

Answer: (59 to 61)

50. The precedence relations and duration (in days) of activities of a project network are given in the table. The total float (in days) of activities e and f, respectively, are

Activity	Predecessors	Duration (days)
a	-	2
b	-	4
c	a	2
d	b	3
e	c	2
f	c	4
g	d,e	5

- (A) 0 and 4 (B) 1 and 4 (C) 2 and 3 (D) 3 and 1

Answer: (B)

51. At a work station, 5 jobs arrive every minute. The mean time spent on each job in the work station is 1/8 minute. The mean steady state number of jobs in the system is _____.

Answer: (1.62 to 1.70)

52. A GO-No GO plug gauge is to be designed for measuring a hole of nominal diameter 25 mm with a hole tolerance of ± 0.015 mm. Considering 10% of work tolerance to be the gauge tolerance and no wear condition, the dimension (in mm) of the GO plug gauge as per the unilateral tolerance system is

- (A) $24.985^{+0.003}_{-0.003}$ (B) $25.015^{+0.000}_{-0.006}$ (C) $24.985^{+0.003}_{-0.003}$ (D) $24.985^{+0.003}_{-0.000}$

Answer: (D)

53. A cylindrical riser of 6 cm diameter and 6 cm height has to be designed for a sand casting mould for producing a steel rectangular plate casting of 7 cm \times 10 cm \times 2 cm dimensions having the total solidification time of 1.36 minute. The total solidification time (in minute) of the riser is _____

Answer: (2.5 to 4.5)

54. A cast iron block of 200 mm length is being shaped in a shaping machine with a depth of cut of 4 mm, feed of 0.25 mm/stroke and the tool principal cutting edge angle of 30° . Number of cutting strokes per minute is 60. Using specific energy for cutting as 1.49 J/mm^3 , the average power consumption (in watt) is _____.

Answer: (295 to 305)

55. A butt weld joint is developed on steel plates having yield and ultimate tensile strength of 500 MPa and 700 MPa, respectively. The thickness of the plates is 8 mm and width is 20 mm. Improper selection of welding parameters caused an undercut of 3 mm depth along the weld. The maximum transverse tensile load (in kN) carrying capacity of the developed weld joint is _____.

Answer: (68 to 72)

★★★ END OF THE PAPER ★★★