

Time : 3 hours

PART I

Maximum Marks : 200

SECTION - A

1. This questions 1.1 to 1.7 below one or more the alternatives are correct. Write the code letter(s), (A,B, C and D) corresponding to the correct alternatives in the answer book. Marks will be given only if all the correct alternatives have been selected and no incorrect alternative is picked up.

1.1 The eigen vector(s) of the matrix $\begin{pmatrix} 0 & 0 & 0 \\ 0 & 0 & 0 \\ 0 & 0 & 0 \end{pmatrix}$, $a \neq 0$, is/are:

- (a) $(0,0,\alpha)$ (b) $(\alpha,0,0)$ (c) $(0,0,1)$ (d) $(0,\alpha,0)$

1.2 The differential equation, $\frac{d^2y}{dx^2} + \frac{dy}{dx} + \sin y = 0$, is:

- (a) linear (b) non-linear (c) homogeneous (d) of degree two

1.3 Simpson's rule for integration gives exact result when $f(x)$ is a polynomial of degree

- (a) 1 (b) 2 (c) 3 (d) 4

1.4 Which of the following is (are) valid FORTRAN 77 statement(s)?

- (a) DO 131 = 1 (b) A = DIM***7 (c) READ = 15.0 (d) GOTO 3 = 10

1.5 Fourier series of the periodic function (period 2π) defined by

$$f(x) = \begin{cases} 0 & -\pi < x < 0 \\ x & 0 < x < \pi \end{cases} \text{ is}$$

$$\frac{\pi}{4} + \sum_1^{\infty} \left[\frac{1}{\pi} n^2 \left(\cos n\pi - 1 \cos nx - \frac{1}{n} \cos n\pi \sin nx \right) \right]$$

By putting $x = \pi$ in the above, one can deduce that the sum of the series

$$1 + \frac{1}{3^2} + \frac{1}{5^2} + \frac{1}{7^2} + \dots, \text{ is}$$

- (a) $\frac{\pi^2}{4}$ (b) $\frac{\pi^2}{6}$ (c) $\frac{\pi^2}{8}$ (d) $\frac{\pi^2}{12}$

1.6 Which of the following improper integrals is (are) convergent?

- (a) $\int_0^1 \frac{\sin x}{1 - \cos x} dx$ (b) $\int_0^{\infty} \frac{\cos x}{1 + x} dx$ (c) $\int_0^{\infty} \frac{x}{1 + x^2} dx$ (d) $\int_0^1 \frac{1 - \cos x}{x^{\frac{5}{2}}} dx$

- 1.7 The function $f(x, y) = x^2y - 3xy + 2y + x$, has
- no local extremum
 - one local minimum but no local maximum
 - one local maximum but no local minimum
 - one local minimum but one local maximum

2. In questions 2.1 to 2.10 below, each blank (_____) is to be suitably filled in. in the answer book write the question number and the answer only. Do not copy the question. Also no explanations for the answers are to be given.

2.1 $\lim_{x \rightarrow 0} \frac{x(e^x - 1) + 2(\cos x - 1)}{x(1 - \cos x)}$ is _____.

2.2 The radius of convergence of the power series $\sum_0^{\infty} \frac{(3m)!}{(m!)^3} x^{3m}$ is _____

2.3 If the linear velocity \vec{V} is given by $\vec{V} = x^2y\hat{i} + xyz\hat{j} - yz^2\hat{k}$ the angular velocity $\vec{\omega}$ at the point (1, 1, -1) is _____.

2.4 Given the differential equation, $\bar{y} = x - y$ with the initial condition $y(0) = 0$. the value of $y(0.1)$ calculated numerically up to the third place of decimal by the second order Runge-Kutta method with step size $h = 0.1$ is _____

2.5 For $X = 4.0$, the value of I in the FORTRAN 77 statement

$$I = -2 ** 2 + 5.0 * X / X * 3 + \frac{3}{4} \text{ is } \underline{\hspace{2cm}}$$

2.6 The value of the double integral $\int_0^{\frac{1}{x}} \int_x^1 \frac{x}{1+y^2} dx dy$ is _____

2.7 If $A = \begin{pmatrix} 1 & 0 & 0 & 1 \\ 0 & -1 & 0 & -1 \\ 0 & 0 & i & i \\ 0 & 0 & 0 & -i \end{pmatrix}$

The matrix A^4 , calculated by the use of Coyley - Mamilton theorem or otherwise, is _____

2.8 Given, $V = x \cos^2 y \hat{i} + x^2 e^x \hat{j} + z \sin^2 y \hat{k}$ and S the surface of a unit cube with one corner at the origin and edges parallel to the coordinate axes, the value of the integral $\iint_S \vec{V} \cdot \hat{n} dS$ is _____

2.9 The differential equation $y'' + \eta y = 0$ is subjected to the boundary conditions $y(0) + 0y(\lambda) = 0$. In order that the equation has non-trivial solution (s), the general value of η is _____

2.10 The Laplace transform of the periodic function $f(t)$ described by the curve below i.e.

$$f(t) = \begin{cases} \sin t & \text{if } (2n-1)\pi \leq t \leq 2n\pi \quad (n=1, 2, 3, \dots) \\ 0 & \text{otherwise} \end{cases}$$

Otherwise is _____

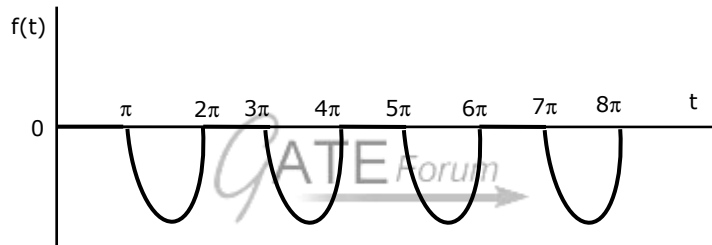

SECTION B: PHYSICS

3. In the following questions 3.1 to 3.17 there are some multiple choice questions and some questions where blanks are to be filled in. Answer ALL the questions. All multiple choice questions have ONE or MORE correct answers those suggested. Credit will be given only if every correct alternative(s), and no incorrect alternative, is selected. Write only the letters corresponding to the select alternatives in the answer book. In the fill in the blank type questions, write the answer only in the answer book.

Useful data: $h = 6.63 \times 10^{-34} \text{ J}_{sc} = 3 \times 10^8 \text{ m/s}$

3.1. Two particles of masses M_1 and M_2 ($M_1 > M_2$) attract each other with a force inversely proportional to the square of the distance between them. The particles are initially at rest and then released. The centre of mass relative to a stationary observer

(a) moves towards M_1 (b) moves towards M_2

(c) remains at rest

(d) moves with a speed proportional to $\sqrt{\frac{M_1}{M_2}}$

- 3.2. The temperature of an ideal gas is held constant while its volume is increased. The pressure exerted by the gas on the walls of the container decreases because its molecules
- strike the walls with smaller force
 - strike the walls with lower velocities
 - strike the walls less frequently
 - collide with each other more frequently
- 3.3. Although a laser beam is highly directional, its beam width increase with propagation. This increase is due to
- coherence
 - diffraction
 - polarization
 - interference
- 3.4. A plane electromagnetic wave of the form
- $$\vec{E} = \hat{y} E_0 \left[\cos 2\pi (5 \times 10^{14} \text{ sec}^{-1}) t - (2.5 \times 10^6 \text{ m}^{-1}) x \right]$$
- Where E_0 is a constant and \hat{y} is the unit vector along y-direction) represents a wave propagating along
- + x direction
 - + y direction
 - x direction
 - y direction
- 3.5. While you are listening to a programme from a radio, if a near by electric light bulb is switched on or switched off, you hear a momentary noise in your radio. This is due to electromagnetic radiation emitted by _____.
- 3.6. Nuclear fusion reactions required very high temperatures so as to overcome
- nuclear forces
 - van der waals forces
 - coulomb forces
 - gravitational forces
- 3.7. In radioactive decay, the disintegration rate of the nuclei is:
- constant at all times
 - inversely proportional to half-life of the nuclei
 - inversely proportional to the number of nuclei at any time
 - directly proportional to the number of nuclei at any time
- 3.8. In an hydrogen atom 10.2 eV is given out as radiation when an electron is de-excited to the ground state. The principal quantum number of the excited state is _____.

- 3.9 Typical current voltage characteristic of a solar cell is given in the following figure by

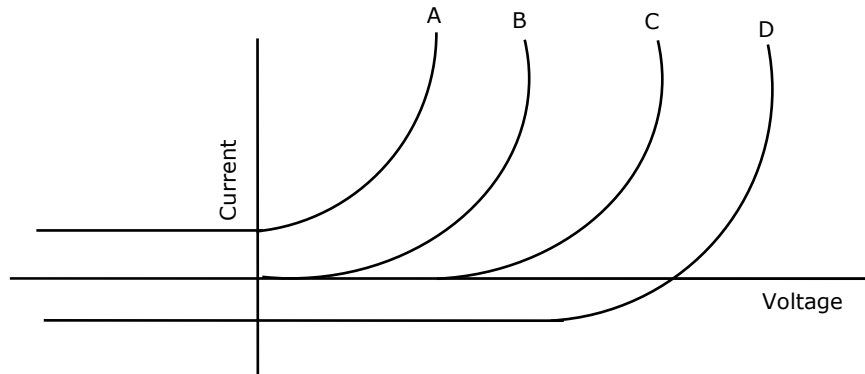

- (a) curve A (b) curve B (c) curve C (d) curve D
- 3.10. Consider a solid sphere and a hollow sphere, both of mass M , radius R and initially at rest, which start rolling down the same inclined plane without slipping. At the bottom of the inclined plane, the ratio of speeds V_{solid} / V_{hollow} is:

- (a) 1 (b) $\sqrt{\frac{12}{7}}$ (c) $\sqrt{\frac{10}{7}}$ (d) $\sqrt{\frac{25}{21}}$

[Note: The moment of inertia about any diameter for a solid sphere is $(2/5) MR^2$, and for a hollow sphere $(2/3) MR^2$].

- 3.11. An optical fibre consists of a cylindrical dielectric rod of refractive index n_1 , surrounded by another dielectric of refractive index n_2 , where $n_2 < n_1$, as shown in the following figure. If a ray is incident from air at an angle i to the axis, then it undergoes total internal reflection at the interface AB if

- (a) $i \geq \sin^{-1} \sqrt{n_1^2 - n_2^2}$
 (b) $i \geq \sin^{-1} \sqrt{n_1 - n_2}$
 (c) $i \leq \sin^{-1} \sqrt{n_1^2 - n_2^2}$
 (d) $i = \sin^{-1} \sqrt{n_1 - n_2}$

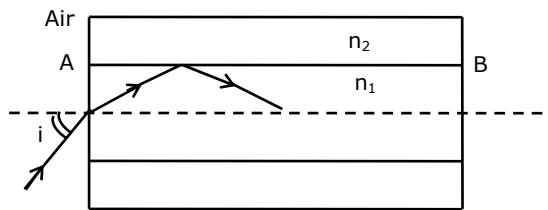

- 3.12. For a uniformly charged sphere of radius R and charge density ρ , the ratio of magnitude of electric fields at distance $\frac{R}{2}$ and $2R$ from the centre, i.e.,

$$\frac{E\left(r = \frac{R}{2}\right)}{E(r = 2R)} \text{ is } \underline{\hspace{2cm}}.$$

SECTION F

4. The questions 4.1 to 4.9 below are multiple choice questions carrying 1 mark each. There could be one or two or more choices for the answer. Indicate your choice by writing the appropriate capital letter/letters against each question number. No credit will be given for writing only one choice in cases where more than one correct answers are possible. Answer the questions 4.1 to 4.9 on one page, in the same order in which they appear.

4.1. A dc circuit shown in figure has a voltage source V , a current source I and several resistors. A particular resistor R dissipates a power of 4 Watts when V alone is active. The same resistor R dissipates a power of 9 Watts when I alone is active. The power dissipated by R when both sources are active will be

- (a) 1 W
- (b) 5 W
- (c) 13 W
- (d) 25 W

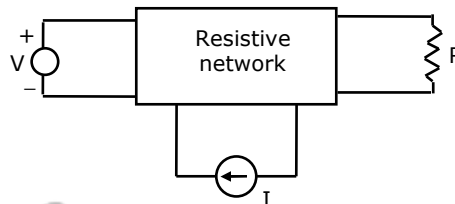

4.2. In the series circuit shown in figure for series resonance, the value of the coupling coefficient K will be

- (a) 0.25
- (b) 0.5
- (c) 0.999
- (d) 1.0

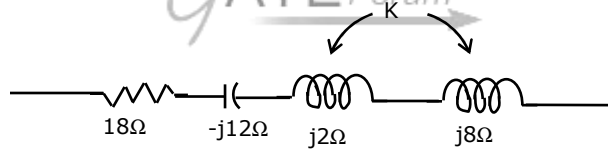

4.3. If the secondary winding of the ideal transformer shown in the circuit of the figure has 40 turns, the number of turns in the primary winding for maximum power transfer to the 2Ω resistor will be

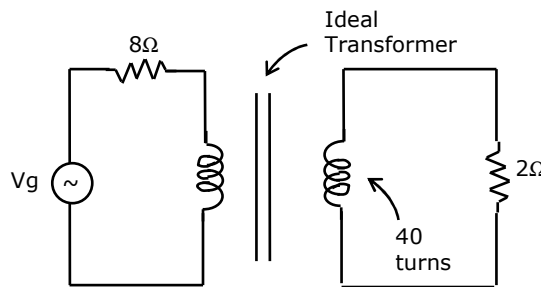

- (a) 20
- (b) 40
- (c) 80
- (d) 160

- 4.4. While starting a dc shunt motor:
- reduced armature voltage V_o and reduced field voltage V_f should be applied and full regulator resistance R_r should be included in the field circuit.
 - reduced V_o but full V_f should be applied and R_r should be zero.
 - rated V_o but rated V_f should be applied and R_r should be zero.
 - rated V_o and rated V_f should be applied and R_r should be maximum.
- 4.5. A 6 pole 3 phase wound rotor induction machine is driven by another machine at 180 rpm. The rotor of the induction machine is connected to a 50 Hz system. If the mechanical rotation of the rotor is in the same direction as the rotor winding flux rotation, then the frequency of the stator voltage will be
- 50 Hz
 - 140 Hz
 - 150 Hz
 - 200 Hz
- 4.6. For the amplifier circuit of figure, the transistor β of 800. The mid-band voltage gain V_o/V_i of the circuit will be

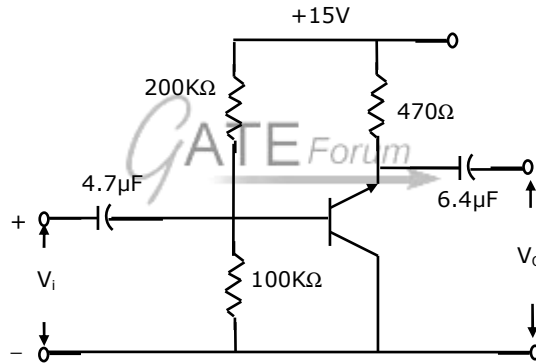

- 0
- < 1
- $= 1$
- 800

- 4.7. The wave shape of V_o in figure will be

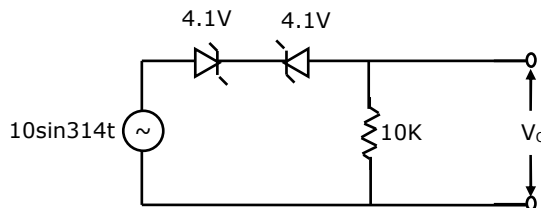

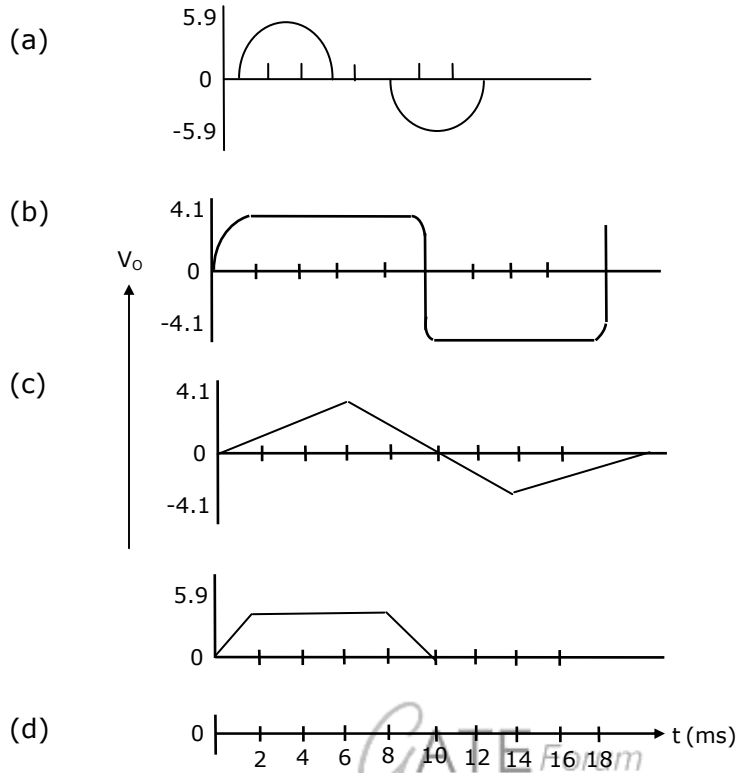

4.8. For the logic circuit shown in figure, the output Y is equal to

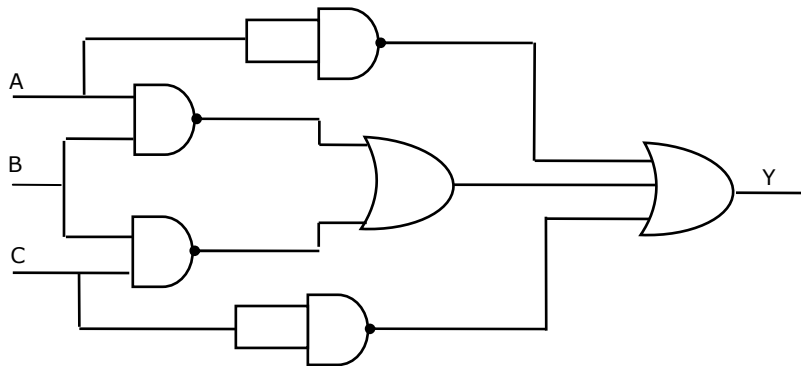

- (a) \overline{ABC} (b) $\overline{A} + \overline{B} + \overline{C}$ (c) $\overline{AB} + \overline{BC} + \overline{A} + \overline{C}$

4.9. In figure, the ideal moving iron voltmeter M will read

- (a) 7.07 V
(b) 12.24 V
(c) 14.14 V
(d) 20.0 V

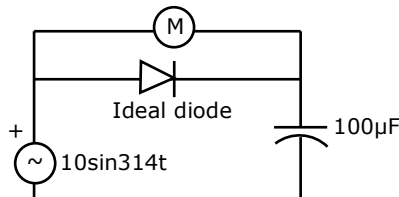

5. The question 5.1 to 5.8 below carry 2 marks each. Give the complete calculation necessary for arriving at the results.

5.1. In the circuit of figure, when switch S_1 is closed, the ideal ammeter M_1 reads 5A. What will be ideal voltmeter M_2 read when S_1 is kept open? (The value of E is not specified).

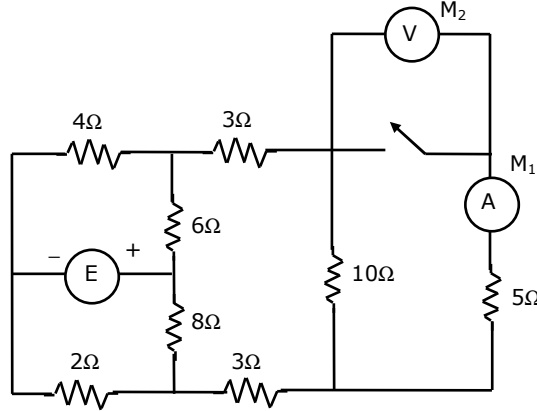

5.2. For the circuit shown in figure, determine the readings of the two wattmeters. Phase sequence is RYB.

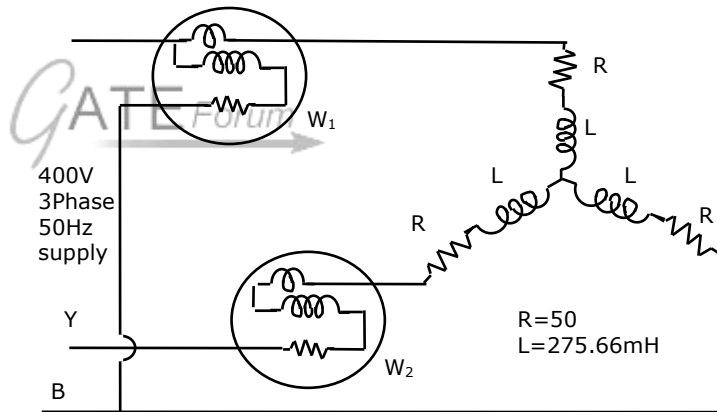

5.3. Figure shows the core and armature of a relay. Flux of 50 mWb is produced in this circuit. Find the force in Newtons acting on the armature. Neglect fringing.

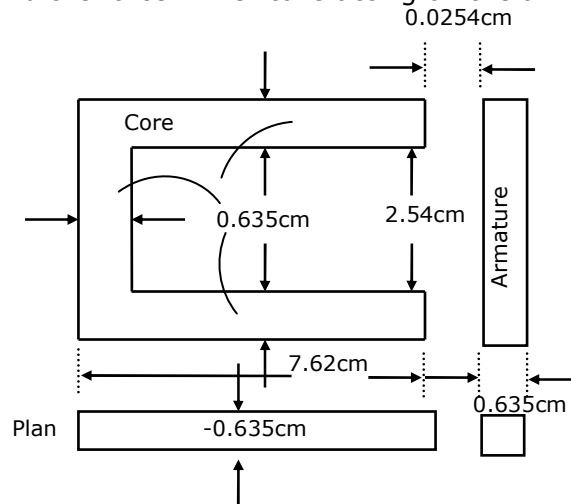

- 5.4. In a 110 volts compound generator, the armature, shunt and series windings are 0.06Ω , 27.5Ω and 0.04Ω respectively. The load consists of 200 lamps each rated at 55W, 110V. Find the total e.m.f an armature current when the machine is connected for long shunt operation.
- 5.5. Two 500 kVA alternators operate in parallel to supply the following loads:
 (i) 250 KW at 0.95 p.f. lagging
 (ii) 100 KW at 0.85 p.f. leading
 One machine is supplying 200 KW at 0.9 p.f. laying. Calculate the p.f. of the other machine.
- 5.6. For the ideal op-amp circuit of figure shown, determine the outpouir voltage V_o .

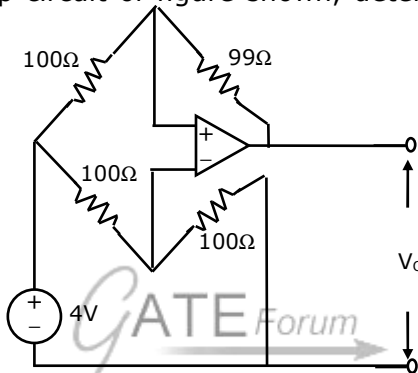

- 5.7. The truth table for the output Y in terms of three inputs A, B and C are given in table. Draw a logic circuit realization using only NOR gates.

A	0	1	0	1	0	1	0	1
B	0	0	1	1	0	0	1	1
C	0	0	0	0	1	1	1	1
Y	1	1	1	0	1	0	0	0

- 5.8. M in figure, is a rectifier type 200 V full scale voltmeter having a sensitivity of $10\text{ k}\Omega/\text{Volt}$. What will be the reading in M if the source voltage V_o is a symmetrical square wave of 800 volts peal to peak?

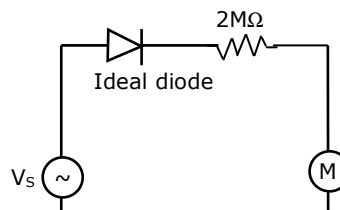

PART II

Read the following instructions carefully:

1. This part contains 16 questions: 6 to 21. Answer all the questions. Question 6 consists of 25 sub-questions each carrying 2 marks. All the sub-questions must be answered in the sequence in which they appear.
2. In the multiple choice questions, four alternatives A, B, C and D are given, of which more than one may be correct. Indicate the correct alternative(s) by writing the corresponding letter (s) in CAPITALS. Marks will be given only if all the correct alternatives are written. For the "Fill in the blanks" type of questions and for questions asking for illustrations, sketches etc. only the answers must be written against the relevant question number in the answer book.
3. Questions 7.21 carry 5 marks each. Answer to each question should appear at one place only. Answers must be neatly and legibly written and well separated from any rough work.
4. Make reasonable assumptions wherever necessary. There is no negative marking.

- 6.1. A network contains linear resistors and ideal voltage sources. If values of all the resistors are doubled, then the voltage across each resistor is
- (a) halved (b) doubled
(c) increased by four times (d) not changed

- 6.2. The two electrical sub network N_1 and N_2 are connected through three resistors as shown in figure. The voltage across 5 ohm resistor and 1 ohm resistor are given to be 10 V and 5V, respectively. Then voltage across 15 ohm resistor is

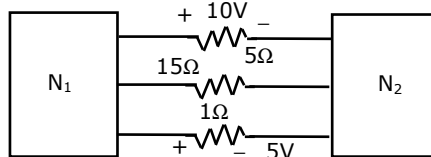

- (a) - 105 V (b) + 105 V (c) - 15 V (d) + 15 V

- 6.3. In figure, A_1, A_2 and A_3 are ideal ammeters? If A_1 reads 5A, A_2 reads 12A, then A_3 should read.

- (a) 7 A
(b) 12 A
(c) 13 A
(d) 17 A

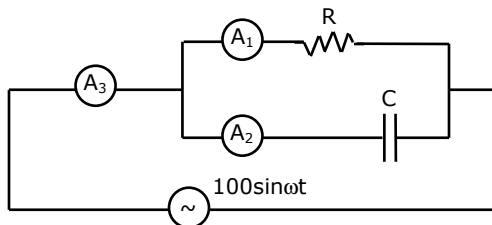

- 6.4. If $\tau F(s) = [f(t)] = \frac{K}{(s+1)(s^2+4)}$ then $\lim_{t \rightarrow \infty} f(t)$ is given by
 (a) $\frac{K}{4}$ (b) zero (c) $0 < A < 12$ (d) $5 < A < 12$
- 6.5. If $s^3 + 3s^2 + 4s + A = 0$, then all the roots of this equation are in the left half plane provided that
 (a) $A > 12$ (b) $-3 < A < 4$ (c) $0 < A < 12$ (d) $5 < A < 12$
- 6.6. The built-in potential (Diffusion Potential) in a p-n junction
 (a) is equal to the difference in the Fermi level of the two sides, expressed in volts.
 (b) increases with the increase in the doping levels of the two sides
 (c) increases with the increase in temperature
 (d) is equal to the average of the Fermi levels of the two sides
- 6.7. α - cut off frequency of a bipolar junction transistor
 (a) increase with the increase in base width
 (b) increases with the increase in emitter width
 (c) increase with increase in the collector width
 (d) increase with decrease in the base width
- 6.8. Negative feedback in amplifiers
 (a) improves the signal to noise ratio at the input
 (b) improves the signal to noise ratio at the output
 (c) does not affect the signal to noise ratio at the output
 (d) reduces distortion
- 6.9. In a multi-stage R-C coupled amplifier the coupling capacitor
 (a) limits the low frequency response
 (b) limits the high frequency response
 (c) does not affect the frequency response
 (d) blocks the d.c. component without affecting the frequency response
- 6.10. The bandwidth of an n-stage tuned amplifier, with each stage having a band width of B, is given by
 (a) $\frac{B}{n}$ (b) $\frac{B}{\sqrt{n}}$ (c) $B\sqrt{2^{\frac{1}{n}} - 1}$ (d) $\frac{B}{\sqrt{2^{\frac{1}{n}} - 1}}$

- 6.11. In a transistor push-pull amplifier
 (a) there is no d.c. present in the output
 (b) there is no distortion in the output
 (c) there are no even harmonics in the output
 (d) there are no odd harmonics in the output
- 6.12. 2's complement representation of a 16-bit number (one sign bit and 15 magnitude bits) is FFFI. Its magnitude in decimal representation is
 (a) 0 (b) 1 (c) 32, 767 (d) 65, 535
- 6.13. Boolean expression for the output of XNOR (Equivalent) logic gate with inputs A and B is:
 (a) $\overline{A}\overline{B} + \overline{A}B$ (b) $\overline{A}\overline{B} + AB$ (c) $(\overline{A} + B)(A + \overline{B})$ (d) $(\overline{A} + \overline{B})(A + B)$
- 6.14. Consider the circuit shown in figure (a). If the diode used here has the V-I characteristic as in figure (b), then the output wave form v_o is:

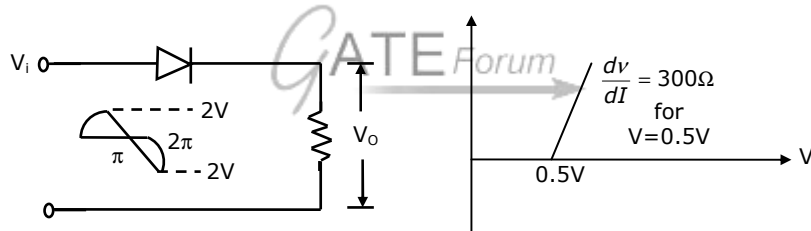

Figure (a)

Figure (b)

- (a)
- (b)
- (c)
- (d)

- 6.15. A pulse train with a frequency of 1 MHz is counted using a modulo 1024 ripple counter built with J-K flip flops. For proper operation of the counter, the maximum permissible propagation delay per flip flop stage is _____ n sec.

- 6.16. In a microprocessor, the register which holds the address of the next instruction to be fetched is:
 (a) accumulator (b) program counter
 (c) stack pointer (d) instruction register
- 6.17. In a microcomputer, wait states are used to
 (a) make the processor wait during a DMA operation
 (b) make the processor wait during an interrupt processing
 (c) make the processor wait during a power shutdown
 (d) interface slow peripherals to the processor

- 6.18. The function shown in figure, can represent a probability density function for A

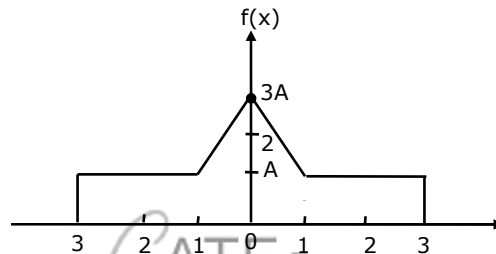

- 6.19. Which of the following demodulator(s) can be used for demodulating the signal $x(t) = 5(1 + 2 \cos 2000\pi t) \cos 2000\pi t$.
 (a) Envelope demodulator (b) square law demodulator
 (c) synchronous demodulator (d) None of the above
- 6.20. A superheterdyne radio receiver with an intermediate frequency of 455 KHz is tuned to a station operating at 1200 KHz. The associated image frequency is _____ KHz.
- 6.21 Sketch the waveform (with properly marked axes) at the output of a matched filter matched for a signal $s(t)$, of duration T, given by

$$S(t) = \begin{cases} A & \text{for } 0 < t < \frac{2}{3}T \\ 6.22 & \text{for } \frac{2}{3}T \leq t < T \end{cases}$$

- 6.22 Six independent low pass signals of bandwidth 3W, W, W, 2W, 3W and 2W Hz are to be time division multiplexed on a common channel using PAM. To achieve this, the minimum transmission bandwidth of the channel should be _____.

- 6.23 A material is described by the following electrical parameters as a frequency of 10 GHz, $\sigma = 10^6$ mho/m, $\mu = \mu_0$ and $\frac{\sigma}{\sigma_0} = 10$. The material at this frequency is considered to be

$$\left(\sigma_0 = \frac{1}{36\pi} \times 10^{-9} F / m \right)$$

- (a) a good conductor
 (b) a good dielectric
 (c) neither a good conductor, nor a good dielectric
 (d) a good magnetic material
- 6.24. Consider a transmission line of characteristic impedance of 50 ohm. Let it be terminated at one end by +j50 ohm. The VSWR produced by it in the transmission line will be

- (a) +1 (b) 0 (c) ∞ (d) +j

- 6.25. A plane wave is incident normally on a perfect conductor as shown in figure. Here $E_x^i = H_y^i$ and \vec{P} are electric field, magnetic field and Poynting vector respectively, for the incident wave. The reflected wave should be

- (a) $E_x^r = -E_x^i$
 (b) $H_y^r = -H_y^i$
 (c) $\vec{P}^r = -\vec{P}^i$
 (d) $E_x^r = E_x^i$

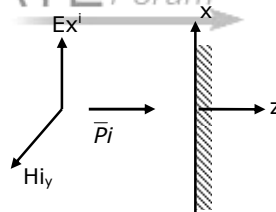

7. An infinite grid is built up by connecting resistors in the manner indicated in figure, where each branch represents one ohm resistor. Calculate the effective resistance between the nodes A and B.

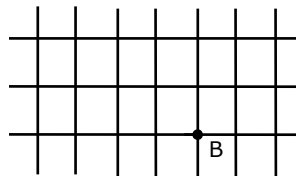

8. Find the Y-parameters (short circuit admittance parameters) for the network shown in figure.

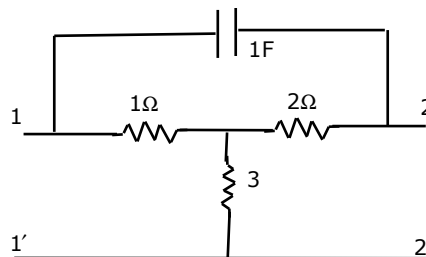

9. Consider the following interconnection of the three LTI systems (figure), $h_1(t)$, $h_2(t)$ and $h_3(t)$ are the impulse responses of these three LTI systems with $H_1(\omega)$, $H_2(\omega)$ and $H_3(\omega)$ as their respective Fourier transforms. Given that

$$h_1(t) = \frac{d}{dt} \left[\frac{\sin \omega_0 t}{2\pi t} \right]$$

$$h_2(t) = \exp \left[\frac{-2\pi\omega}{\omega_0} \right]$$

$$h_3(t) = u(t), \text{ and}$$

$$x(t) = \sin 2\omega_0 t + \cos \left[\frac{\omega_0 t}{2} \right]$$

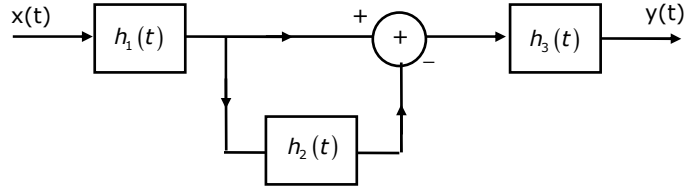

Find the output $y(t)$.

10. The reverse saturation current of the collector base junction (I_{CBO}) of a BJT is found to be 10n A at low collector voltages. The low voltage current amplification factor (α) is 0.98. Find out the change in collector current with its base open (I_{CEO}) when the collector voltage is increased such that α increases by the 1.0%.
11. A JFET with the following parameters is used in a single stage common source amplifier with a load resistance of 100k Ω . Calculate the high frequency cut off (upper 3 dB cut off frequency) of the amplifier.

$$G_m = 2.0 \text{ mA/V}$$

$$C_{gd} = 2.0 \text{ pF}$$

$$r_d = 100 \text{ k}\Omega$$

$$C_{gs} = 2.0 \text{ pF}$$

$$C_{gd} = 1.0 \text{ pF}$$

12. In the following circuit the capacitance varies as $C = KW$, where K is a constant equal to 0.5 Farads/Coulomb and Q, the charge on the capacitor in Coulombs. Determine the current through the circuit and sketch the voltage waveform across the capacitor (V_c) for a step input V_i as shown in figure.

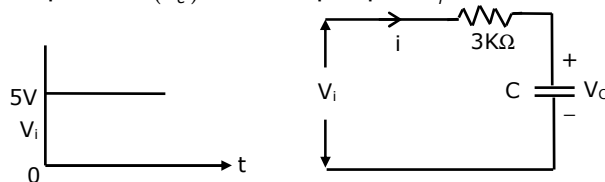

13. Find the output voltage, V_o in the following circuit (figure), assuming that the op-amps are ideal.

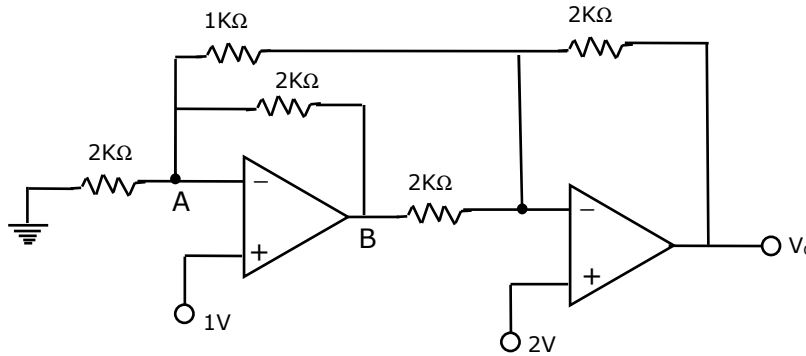

14. Signals A , B , C , D and \bar{D} are available. Using a single 8 to 1 multiplexer and no other gate, implement the Boolean function $f(A, B, C, D) = B.C + A.B.\bar{D} + \bar{A}.\bar{C}.D$
15. A clocked sequential circuit has three states, A , B and C and one input X . As long as the input X is 0, the circuit alternates between the states A and B . If the input X becomes 1 (either in state A or in state B), the circuit goes to state C and remains in state C as long as X continues to be 1. The circuit returns to state A if the input becomes 0 once again and from then on repeats its behaviour. Assume that the state assignments are $A = 00$, $B = 01$ and $C = 10$.
- Draw the state diagram of the circuit
 - Give the state table for the circuit
 - Draw the circuit using D flip flops
16. A microprocessor has five address lines $[A_0 - A_4]$ and eight data lines $[D_0 - D_7]$. An input device A , an output device B , a ROM and a RAM are memory mapped to the microprocessor at the addresses as shown in figure. Devices A and B have four addressable registers each; RAM has 8 bytes and ROM has 16 bytes.

B	1F 1C
ROM	1B 0C
RAM	0B 04
A	03 00

- Indicate the address lines to be connected to each device and memory.
- Obtain the minimum sum of product expression for the chip select (CS) function of each device/memory.

17. It is desired to generate a random signal $x(t)$, with autocorrelation function, $R_x(T) = 5\eta e^{-5|T|}$, by passing white noise $n(t)$, with power spectral density $S_n(f) = \frac{\eta}{2}$ watts / Hz, through a LTI system. Obtain an expression for the transfer function $H(f)$ of the LTI system.

18. Obtain an expression for the signal $v_3(t)$ in figure, for $v_1(t) = 10 \cos(2000\pi t) + 4 \sin(200\pi t)$. Assume that $v_2(t) = v_1(t) + 0.1v_1^2(t)$ and that the BPF is an ideal unity gain filter with pass band from 800 Hz to 1200 Hz.

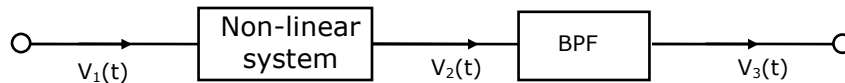

19. A low pass signal $m(t)$ band limited to B Hz is sampled by a periodic rectangular pulse train, $P_r(t)$ of period $T_2 = \frac{1}{(3B)}$ sec. assuming natural sampling and that the pulse amplitude and pulse width are A volts and $\frac{I}{(30B)}$ sec, respectively, obtain expression for the frequency spectrum of the sampled signal $m_2(t)$.

20. Consider an array of two non-directional radiators with spacing $d = 0.5\lambda$. Determine the directions of maximum radiation when the radiators are excited as shown in figure. Calculate the phase shift required for turning the direction of the maximum radiators by 90° , keeping the separation, d , unchanged.

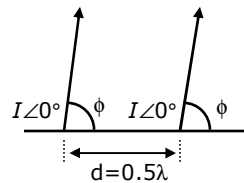

21. Match the following descriptions with each of the diagrams given in figure. Fields are near the interface, but on opposite sides of the boundary. Vectors are drawn to scale.

- (a) Medium 1 and medium 2 are dielectrics with $\epsilon_1 > \epsilon_2$
- (b) Medium 1 and medium 2 are dielectrics with $\epsilon_1 < \epsilon_2$
- (c) Medium 2 is a perfect conductor
- (d) Medium 1 is a perfect conductor.

