

SECTION - A

1. This question consists of 25 (TWENTTY FIVE) sub-questions. Each sub-question carries ONE mark. The answers to these sub-questions MUST be written only in the appropriate boxes corresponding to the questions in the first page of the answer book.
- 1.1 An electron with velocity u is placed in an electric field E and magnetic field B . the force experienced by the electron is given by
 (a) $-eE$ (b) $-eu \times B$ (c) $-e(u \times E + B)$ (d) $-e(E + u \times B)$

- 1.2 A voltage waveform $V(t) = 12t^2$ is applied across a 1H inductor for $t \geq 0$, with initial current through it being zero. The current through the inductor for $t \geq 0$ is given by
 (a) $12t$ (b) $24t$ (c) $12t^3$ (d) $4t^3$

- 1.3 The circuit shown in Fig.1.3 uses an ideal opamp working with +5V and -5V power supplies. The output voltage V_o is equal to

- (a) +5V
 (b) -5V
 (c) +1V
 (d) -1V

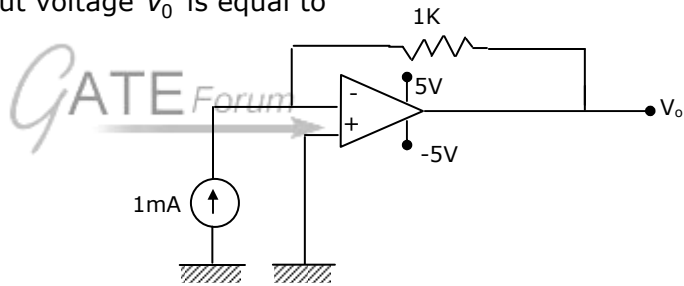

- 1.4 Which one of the following is not a vectored interrupt?
 (a) TRAP (b) INTR (c) RST7.5 (d) RST3
- 1.5 The type of power amplifier which exhibits crossover distortion in its output is
 (a) Class A (b) Class B (c) Class AB (d) Class C
- 1.6 The feedback factor for the circuit shown in Fig.1.6 is:

- (a) $\frac{9}{100}$
 (b) $\frac{9}{10}$
 (c) $\frac{1}{9}$
 (d) $\frac{1}{10}$

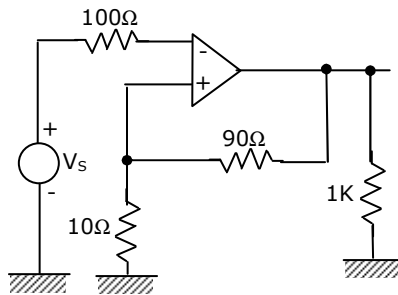

- 1.7 A 3-phase, 4-pole squirrel cage induction motor has 36 stator and 28 rotor slots. The number of phases in the rotor is:
(a) 3 (b) 9 (c) 7 (d) 8
- 1.8 The compensating winding in a dc machine
(a) is located in armature slots for compensation of the armature reaction
(b) is located on commutating poles for improving the commutation
(c) is located on pole shoes for avoiding the flashover at the commutator surface
(d) is located on poles shoes to avoid the sparking at the brushes.
- 1.9 In a constant voltage transformer (CVT), the output voltage remains constant due to
(a) capacitor (b) input inductor
(c) saturation (d) tapped windings
- 1.10 The phase sequence of a three-phase alternator will reverse if
(a) the field current is reversed keeping the direction of rotation same
(b) the field current remains the same but the direction of rotation is reversed
(c) the field current is reversed and the number of poles is doubled
(d) the number of poles is doubled without reversing the field current
- 1.11 A 1.8° step, 4-phase stepper motor has a total of 40 teeth on 8 poles of stator. The number of rotor teeth for this motor will be
(a) 40 (b) 50 (c) 100 (d) 80
- 1.12 In a thermal power plant, the feed water coming to the economizer is heated using
(a) H.P. steam (b) L.P. steam
(c) direct heat in the furnace (d) flue gases
- 1.13 For given base voltage and base volt-amperes, the per unit impedance value of an element is x . What will be the per unit impedance value of this element when the voltage and volt-ampere bases are both doubled?
(a) $0.5x$ (b) $2x$ (c) $4x$ (d) x
- 1.14 In an inverse definite minimum time, electromagnetic type over-current relay the minimum time feature is achieved because of
(a) saturation of the magnetic circuit (b) proper mechanical design
(c) appropriate time delay element (d) electromagnetic damping

- 1.15 Out of the considerations (a) to (d) listed below.
- (i) no distance limitation related to steady state stability
 - (ii) no reactive power requirement from the system at the two terminals
 - (iii) no substantial effect on fault level of the two systems at the terminals inspite of the interconnection
 - (iv) no corona problems
- The considerations, which constitute advantages of HVDC transmission, are
- (a) all of the above (b) (i) and (iii) (c) (iii) and (iv) (d) (ii) and (iv)
- 1.17 In a 3-step distance protection, the reach of the three zones of the relay at the beginning of the first line typically extends up to
- (a) 100% of the first line, 50% of the second line and 20% of the third line
 - (b) 80% of the first line, 50% of the second line and 20% of the third line
 - (c) 80% of the first line, 20% of the second line and 10% of the third line
 - (d) 50% of first line, 50% of second line and 20% of the third line.
- 1.17 A three phase semi-converter feeds the armature of a separately excited dc motor, supplying a non-zero torque. For steady state operation, the motor armature current is found to drop to zero at certain instances of time. At such instances, the voltage assumes a value that is
- (a) equal to the instantaneous value of the ac phase voltage
 - (b) equal to the instantaneous value of the motor back emf
 - (c) arbitrary
 - (d) zero
- 1.18 A thyristorised, three phase, fully controlled converter feeds a dc load that draws a constant current. Then the input ac line current to the converter has
- (a) an rms value equal to the dc load current
 - (b) an average value equal to the dc load current
 - (c) a peak value equal to the dc load current
 - (d) a fundamental frequency component, whose rms value is equal to the dc load current
- 1.19 Triangular PWM control, when applied to a three phase, BJT based voltage source inverter, introduces
- (a) low order harmonic voltages on the dc side
 - (b) very high order harmonic voltages on the dc side
 - (c) low order harmonic voltages on the ac side
 - (d) very high order harmonic voltage on the dc side

- 1.20 Instrument transformers are known to introduce magnitude and phase errors in measurements. These are primarily due to
- improper connections on the primary side
 - measurement errors inherent in the meter connected to the transformer secondary
 - open and short circuit parameters of the instrument transformers
 - None of the above
- 1.21 An analogue electronic circuit that measures rms value of the input voltage by averaging the square of the instantaneous voltage level, responds slowly to changes in the input signal due to
- the "square" function built into the circuit
 - the "square-root" function built into the circuit
 - the averaging function built into the circuit
 - None of the above
- 1.22 Ratio of the rotor reactance X to the rotor resistance R for a two-phase servomotor
- is equal to that of a normal induction motor
 - is less than that of a normal induction motor
 - is greater than that of a normal induction motor
 - may be less or greater than that of a normal induction motor
- 1.23 Feedback control systems are
- insensitive to both forward and feedback path parameter changes
 - less sensitive to feedback path parameter changes than to forward path parameter changes
 - less sensitive to forward-path parameter changes than to feedback path parameter changes
 - equally sensitive to forward and feedback path parameter changes
- 1.24 A unity feedback system has open loop transfer function $G(s)$. The steady-state error is zero for
- | | |
|-----------------------------------|-----------------------------------|
| (a) step input and type $-1 G(s)$ | (b) ramp input and type $-1 G(s)$ |
| (c) step input and type $G(s)$ | (d) ramp input and type $-0 G(s)$ |
- 1.25 A linear time-invariant system initially at rest, when subjected to a unit-step input, gives a response $y(t) = te^{-t}, t > 0$. The transfer function of the system is:
- | | | | |
|-------------------------|--------------------------|-------------------------|------------------------|
| (a) $\frac{1}{(s+1)^2}$ | (b) $\frac{1}{s(s+1)^2}$ | (c) $\frac{s}{(s+1)^2}$ | (d) $\frac{1}{s(s+1)}$ |
|-------------------------|--------------------------|-------------------------|------------------------|

2. This question consists of 25 (TWENTY FIVE) sub-questions. Each sub-question carries TWO marks. The answers to these sub-questions MUST be written only in the appropriate boxes corresponding to the questions in the first page of the answer book.

- 2.1 A two-port device is defined by the following pair of equations:

$$i_1 = 2v_1 + v_2 \text{ and } i_2 = v_1 + v_2$$

Its impedance parameters ($z_{11}, z_{12}, z_{21}, z_{22}$) are given by

- (a) (2,1,1,1) (b) (1,-1,-1,2) (c) (1,1,1,2) (d) (2,-1,-1,1)

- 2.2. The circuit shown in Fig.2.2 is equivalent to a load of

- (a) $\frac{4}{3}$ ohms
(b) $\frac{8}{3}$ ohms
(c) 4 ohms
(d) 2 ohms

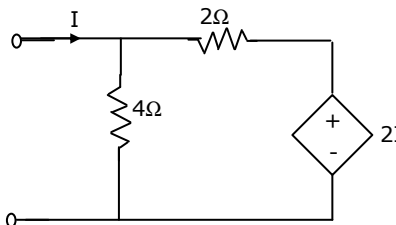

- 2.3. The impedance seen by the source in the circuit in Fig.2.3, is given by

- (a) $(0.54 + j0.313)$ ohms
(b) $(4 - j2)$ ohms
(c) $(4.54 - j1.69)$ ohms
(d) $(4 + j2)$ ohms

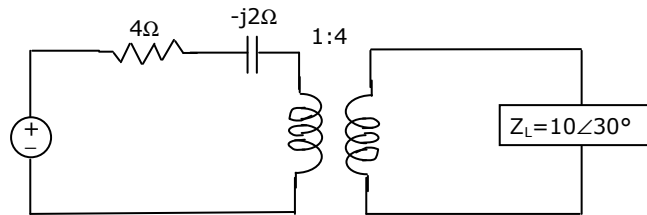

- 2.4. The minimal product of sums function described by the K-map given in Fig.2.4

- (a) $A'C'$
(b) $A' + C'$
(c) $A + C$
(d) AC

		AB			
		00	01	11	10
C	0	1	1	ϕ	0
	1	0	0	ϕ	0

- 2.5. A diode whose terminal characteristics are related as $i_D = I_s \left(\frac{V}{V_T} \right)$, where I_s is the reverse saturation current and V_T is the thermal voltage ($=25\text{mV}$), is biased at $I_D = 2\text{mA}$. Its dynamic resistance is:

- (a) 25 ohms (b) 12.5 ohms (c) 50 ohms (d) 100 ohms

- 2.6. In the circuit of Fig.2.6, the value of the base current I_B will be
- 0.0 micro amperes
 - 18.2 micro amperes
 - 26.7 micro amperes
 - 40.0 micro amperes

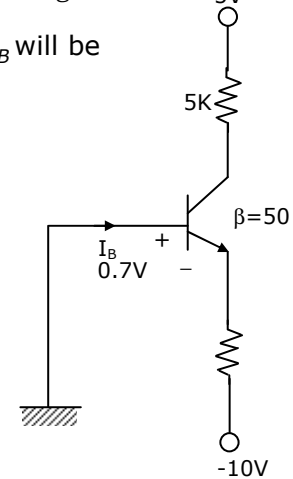

- 2.7. A dual slope analog-to-digital converters uses an N-bit counter. when the input signal V_a is being integrated, the counter is allowed to count up to a value
- equal to $2^N - 2$
 - equal to $2^N - 1$
 - proportional to V_a
 - inversely proportional to V_a
- 2.8. A 3-phase delta/star transformer is supplied at 6000 V on the delta-connected side. The terminal voltage on the secondary side when supplying full load as 0.8 lagging power-factor is 415 V. The equivalent resistance and reactance drops for the transformer are 1% and 5% respectively. The turn's ratio of the transformer is:
- 14
 - 24
 - 42
 - 20
- 2.9. A 240 V dc series motor takes 40A when giving its rated output at 1500 rpm. Its resistance is 0.3 ohms. The value of resistance which must be added to obtain rated torque at 1000 rpm is:
- 6 ohms
 - 5.7 ohms
 - 2.2 ohms
 - 1.9 ohms
- 2.10. The power input to a 415V, 50 Hz, 6 pole, 3-phase induction motor running at 975 rpm is 40 kW. The stator losses are 1kW and friction and windage losses total 2 kW. The efficiency of the motor is
- 92.5%
 - 90%
 - 91%
 - 88%
- 2.11. A single-phase, 2000V alternator has armature resistance and reactance of 0.8 ohms and 4.94 ohms respectively. The voltage regulation of the alternator at 100A load at 0.8 leading power-factor is:
- 7%
 - 8.9%
 - 14%
 - 0%

- 2.12. A permanent magnet dc commutator motor has a no load speed of 6000 rpm when connected to a 120V dc supply. The armature resistance is 2.5 ohms and other losses may be neglected. The speed of the motor with supply voltage of 60V developing a torque 0.5 Nm, is:
 (a) 3000 rpm (b) 2673 rpm (c) 2836 rpm (d) 5346 rpm
- 2.13. A transmission line has equal voltages at the two ends, maintained constant by two sources. A third source is to be provided to maintain constant voltage (equal to end voltages) at either the midpoint of the line or at 75% of the distance from the sending end. Then the maximum power transfer capabilities of the line in the original case and the other two cases respectively will be in the following ratios.
 (a) 1:1:1 (b) 1:2: $\frac{1}{0.75}$ (c) 1:2:4 (d) 1:4:16
- 2.14. The plug setting of a negative sequence relay is 0.2A. The current transformer ratio is 5:1. The minimum value of line-to-line fault current for the operation of the relay is
 (a) 1A (b) $\frac{1}{1.732}$ A (c) 1.732A (d) $\frac{0.2}{1.732}$ A
- 2.15. The incremental cost characteristics of two generators delivering 200 MW are as follows

$$\frac{dF_1}{dP_1} = 2.0 + 0.01P_1, \frac{dF_2}{dP_2} = 1.6 + 0.2P_2$$
 For economic operation, the generations P_1 and P_2 should be
 (a) $P_1 = P_2 = 100MW$ (b) $P_1 = 80MW, P_2 = 120MW$
 (c) $P_1 = 200MW, P_2 = 0MW$ (d) $P_1 = 120MW, P_2 = 80MW$
- 2.16. The corona loss on a particular system at 50 Hz is 1kW/km per phase. The corona loss at 60 Hz would be
 (a) 1kW/km per phase (b) 0.83kW/km per phase
 (c) 1.2kW/km per phase (d) 1.13kW/km per phase
- 2.17. The severity of line-to-ground and three phase faults at the terminals of an unloaded synchronous generator is to be same. If the terminal voltage is 1.0 p.u. and $Z_1 = Z_2 = j0.1p.u., Z_0 = j0.05p.u.$ for the alternator, then the required inductive reactance for neutral grounding is:
 (a) 0.0166 p.u. (b) 0.05 p.u. (c) 0.1 p.u. (d) 0.15 p.u.

- 2.18. A three phase voltage source inverter supplies a purely inductive three phase load. Upon Fourier analysis, the output voltage waveform is found to have an h -th order harmonic of magnitude α_h times that of the fundamental frequency component ($\alpha_h < 1$). The load current would then have an h -th order harmonic of magnitude
- zero
 - α_h times the fundamental frequency component
 - $h\alpha_h$ times the fundamental frequency component
 - $\alpha_h h$ times the fundamental frequency component
- 2.19. A step down chopper operates from a dc voltage source V_s , and feeds a dc motor armature with a back emf E_b . From oscilloscope traces, it is found that the current increases for time t_r , falls to zero over time t_f , and remains zero for time t_0 , in every chopping cycle. Then the average dc voltage across the freewheeling diode is:
- $\frac{V_s t_r}{(t_r + t_f + t_0)}$
 - $\frac{(V_s t_r + E_b t_f)}{(t_r + t_f + t_0)}$
 - $\frac{(V_s t_r + E_b t_0)}{(t_r + t_f + t_0)}$
 - $\frac{V_s t_r + E_b (t_f + t_0)}{(t_r + t_f + t_0)}$
- 2.20. A three phase, wound rotor induction motor is to be operated with slip energy recovery in the constant torque mode, when it delivers an output power P_0 at slip s . then theoretically, the maximum power that is available for recovery at the rotor terminals, is equal to
- P_0
 - $P_0 s$
 - $\frac{P_0}{(1-s)}$
 - $\frac{P_0 s}{(1-s)}$
- 2.21. The two wattmeter method is used to measure active power on a three phase, three wire system. If the phase voltage is unbalanced, then the power reading is:
- affected by both negative sequence and zero sequence voltages
 - affected by negative sequence voltages but not by zero sequence voltages
 - affected by zero sequence voltages but not by negative sequence voltages
 - not affected by negative or zero sequence voltages
- 2.22. If an ac voltage wave is corrupted with an arbitrary number of harmonics, then the overall voltage waveform differs from its fundamental frequency component in terms of
- only the peak values
 - only the rms values
 - only the average values
 - all the three measures (peak, rms and average values)

2.23. The characteristic equation of a feedback control system is:

$$2s^4 + s^3 + 3s^2 + 5s + 10 = 0$$

The number of roots in the right half of s-plane are:

- (a) zero (b) 1 (c) 2 (d) 3

2.24. A unity feedback system has open-loop transfer function $G(s) = \left\{ \frac{25}{[s(s+6)]} \right\}$.

The peak overshoot in the step-input response of the system is approximately equal to:

- (a) 5% (b) 10% (c) 15% (d) 20%

2.25. Maximum phase-lead of the compensator $D(s) = \frac{(0.5s + 1)}{(0.05s + 1)}$, is

- (a) 52 deg at 4 rad/sec (b) 52 deg at 10 rad/sec
(c) 55 deg at 12 rad/sec (d) None of the answers is correct

SECTION - B

This section consists of TWENTY questions of FIVE marks each. ANY FIFTEEN out of them have to be answered. If more number of questions are attempted, score off the answers not be evaluated, else, only the first fifteen unscored answers will be considered.

3. Predict the current I in Fig.3 in response to a voltage of $20\angle 0^\circ$ V. The impedance values are given in ohms. Use the thevenin's theorem.

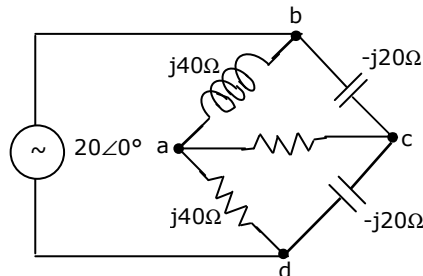

4. (a) Show via the construction of a suitable Gaussian surface, that the capacitance of a spherical capacitor consisting of two concentric shells of radii a and b is given by

$$C = 4\pi\epsilon_0 \frac{ab}{(b - a)}$$

where ϵ_0 is the free space permittivity.

- (b) A current i in the short conducting element shown in Fig.4 produces a flux density B_1 at point 1. Determine the magnitude and the direction of the flux density vector at point 2.

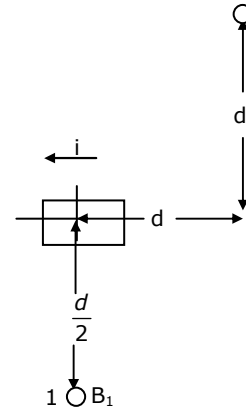

5. A current amplifier has an input resistance of 10Ω , an output resistance of $10k\Omega$ and a current gain of 1000. It is fed by a current source having a source resistance of $10k\Omega$ and its output is connected to a 10Ω load resistance. Find the voltage gain and the power gain.

6. An active filter consisting of an op-amp, resistors R_1, R_2, R_3 and two capacitors of value C each, has a transfer function

$$T(s) = \frac{-s}{(R_1 C)} \frac{1}{s^2 + \frac{2s}{(R_3 C)} + \frac{1}{(R R_3 C^2)}}, \text{ where } R = R_1 \square R_2.$$

If $R_1 = 2k\Omega$, $R_2 = \frac{2}{3}k\Omega$, $R_3 = 200k\Omega$ and $C = 0.1 \mu F$, determine the centre frequency ω_0 , gain A_0 and the Q of the filter.

7. The counter shown in Fig.7 is initially in state $Q_2 = 0, Q_1 = 1, Q_0 = 0$. With reference to the CLK input, draw waveforms for Q_2, Q_1, Q_0 and P for the next three CLK cycles.

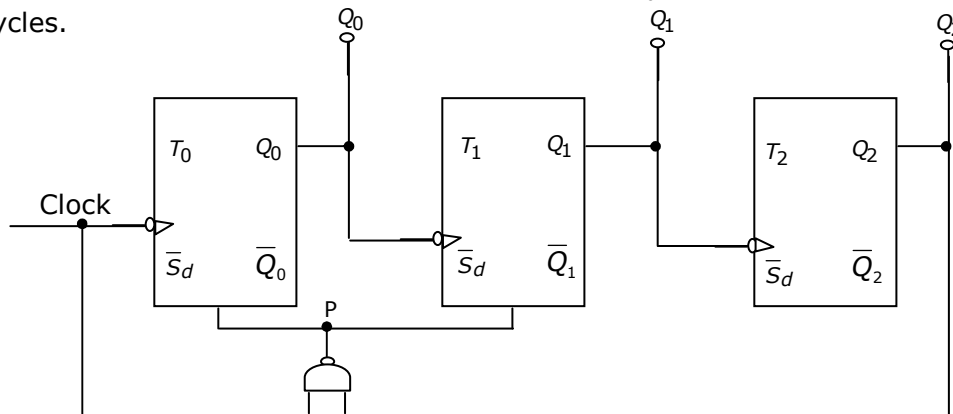

8. In a single-phase, three-winding transformer, the turns ratio for primary: secondary: tertiary windings is 20:4:1. With the lagging currents of 50A at a power factor of 0.6 in the tertiary winding, find the primary current and power-factor.

9. A belt driven dc shunt generator runs at 1500 rpm delivering 10kW, at 220V bus bars. The belt breaks, following which the machine operates as a motor drawing 2kW power. What will be its speed as a motor? The armature and field resistances are 0.25 ohms and 55 ohms respectively. Ignore armature reaction and assume the contact drop at each brush to be 1V.
10. A 230V, 20 hp, 60 Hz, 6-pole, 3-phase induction motor driving a constant torque load at rated frequency, rated voltage and rated horse-power, has a speed of 1175 rpm and an efficiency of 92.1%. Determine the new operating speed if a system disturbance causes 10% drop in voltage and 6% drop in frequency. Assume that friction, windage and stray power losses remain constant.
11. A 2300 V, 3-phase synchronous motor driving a pump is provided with a line ammeter and a field rheostat. When the rheostat is adjusted such that the ac line current is minimum. The ammeter reads 8.8A. What is the power being delivered to the pump, neglecting losses? How should the rheostat be adjusted so that the motor operates at 0.8 leading power factor? How many kVARs is the motor supplying to the system at this new power factor?
12. A 275 kV, 3-phase, 50 Hz, 400 km lossless line has following parameters:
 $x=0.05$ ohms/km, line charging susceptance $y=3.0$ micro-Siemens/km.
 - (a) Calculate the receiving end voltage on open circuit using justifiable assumptions.
 - (b) What load at the receiving end will result in a flat voltage profile on the line?
 - (c) If the flat voltage profile is to be achieved at 1.2 times the loading in (b), what will be the nature and quantum of uniformly distributed compensation required?
13. In a 3-bus system, Gauss load flow method is to be used for finding the switched capacitor compensation required to maintain the voltage at bus 2 equal to 1.0 p.u. the data for the system is as follows:

Line data: $Z_{12} = Z_{13} = Z_{31} = j0.1$ p.u. Neglect line charging.

Bus data:

Bus No.	Bus Type	Specifications
1	Slack	$V_1 = (1 + j0) p.u.$
2	PV	Load: $P_2 + jQ_2 = (0.4 + j0.2) p.u.$ V_2 (magnitude) = 1.0 p.u.
3	PQ	Load: $P_3 + jQ_3 = (0.3 + j0.15) p.u.$

All data are on common base values.

With the help of one iteration of load flow, explain how you will achieve the stated objective.

14. For the configuration shown in Fig.14, the breaker connecting a large system to bus 2 is initially open. The system 3-phase fault level at bus 3 under this condition is not known. After closing the system breaker, the 3-phase fault level at bus 1 was found to be 5.0 p.u. What will be the new 3-phase fault level at system bus 3 after the interconnection? All per unit values are on common bases. Prefault load currents are neglected and prefault voltages are assumed to be 1.0 p.u. at all buses.

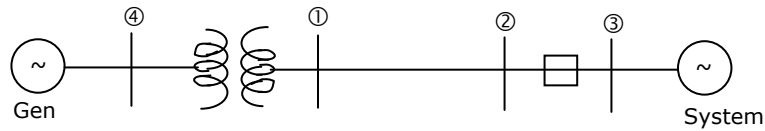

$$E_g = 1.0 \text{ p.u. } X_r = 0.2 \text{ p.u.}$$

$$X_{\text{Line}} = 0.3 \text{ p.u. } X_d = 0.2 \text{ p.u.}$$

15. A synchronous generator, having a reactance of 0.15 p.u., is connected to an infinite bus through two identical parallel transmission lines having reactance of 0.3 p.u. each. In steady state, the generator is delivering 1 p.u. Power to the infinite bus. For a three-phase fault at the receiving end of one line, calculate the rotor angle at the end of first time step of 0.05 seconds. Assume the voltage behind transient reactance for the generator as 1.1 p.u. and infinite bus voltage as 1.0 p.u. Also indicate how the accelerating powers will be evaluated for the next time step if the breaker clears the fault
- (a) at the end of an interval
(b) at the middle of an interval
16. A single phase voltage source of magnitude V_s and frequency ω (rad/s) is connected to an inductance L through an antiparallel back-to-back pair of thyristors. The forward and reverse conducting thyristors are fired at an angle of $\alpha \geq \frac{\pi}{2}$ from the positive going and negative going zero crossings of the supply voltage respectively, in each cycle.
Obtain an expression for the inductor current in each cycle for a given value of α .
The voltage drop across the thyristors, when either of them is in conduction, may be assumed to be negligible.
17. A dc motor with armature resistance R_a is fed from a step down chopper in the continuous mode, and operates at some known speed and known excitation current. The motor current rises from I_{\min} to I_{\max} in the ON period T_{on} of the chopper; and drops from I_{\max} to I_{\min} in the OFF period T_{off} of the same circuit. Both the rise and fall of the current may be assumed to be approximately linear. What is the average power loss in the machine armature?

18. For perfectly balanced operation a certain three phase ac power electronic circuit generates odd harmonic currents of order five and seven in the three phases of the ac mains. Identify which of these harmonics form a positive-sequence system, and which form a negative-sequence system.

19. A three-phase load operates with balanced voltages applied to its terminals, and draws balanced currents. The potential coil of a moving coil wattmeter is connected from R to Y terminals of the load. The current coil of the meter is connected in series with phase B. by appropriate derivation, show that the quantity indicated by this wattmeter is proportional to the reactive power drawn by the load.

20. Open-loop transfer function of a unity-feedback system is:

$$G(s) = G_1(s) \cdot e^{-s\tau_D} = \frac{e^{-s\tau_D}}{s(s+1)(s+2)}$$

Given: $|G_1(j\omega)| = 1$ when $\omega = 0.466$.

- Determine the phase margin when $\tau_D = 0$.
- Comment in one sentence on the effect of dead time on the stability of the system.
- Determine the maximum value of dead time τ_D for the closed-loop system to be stable.

21. A unity feedback system has open-loop transfer function

$$G(s) = \frac{K(s+5)}{s(s+2)}; K \geq 0$$

- Draw a rough sketch of the root locus plot; given that the complex roots of the characteristic equation move along a circle.
- As K increases, does the system become less stable? Justify your answer.
- Find the value of K (if it exists) so that the damping ξ of the complex closed loop poles is 0.3.

22. Consider the state equation

$$\dot{x}(t) = Ax(t)$$

Given:

$$e^{At} = \begin{bmatrix} e^{-t} + te^{-t} & te^{-t} \\ -te^{-t} & e^{-t} - te^{-t} \end{bmatrix}$$

- Find a set of states $x_1(1)$ and $x_2(1)$ such that $x_1(2) = 2$.
- Show that

$$(sI - A)^{-1} = \Phi(s) = \frac{1}{\Delta} \begin{bmatrix} s+2 & 1 \\ -1 & s \end{bmatrix}; \Delta = (s+1)^2$$

- From $\Phi(s)$, find the matrix A.